

PFAFF

1295

1296

Teilleiste

Parts list

Liste de pièces

Lista de piezas

3713-2/01

Diese Teilleiste hat für Maschinen ab nachfolgender
Seriennummer Gültigkeit:

This parts list applies to machines from the following
serial numbers onwards:

Cette liste de pièces est valable pour les machines au
numéros de série à partir de:

Esta lista de piezas tiene validez para máquinas a partir del
número de serie siguiente:

PFAFF 1295 # 2580318 →

PFAFF 1296 # 2580350 →

PFAFF 3713 # 2226093 →

Alle Informationen und Abbildungen waren zum Zeitpunkt der Druckgebung auf dem neusten Stand.

Technische Änderungen vorbehalten!

Der Nachdruck, die Vervielfältigung sowie die Übersetzung - auch auszugsweise - aus PFAFF-Teilelisten ist nur mit unserer vorherigen Zustimmung und mit der Quellenangabe gestattet.

At the time of printing, all information and illustrations contained in this document were up to date.

Subject to alteration!

The reprinting, copying or translation of PFAFF Parts lists whether in whole or in part, is only permitted with our previous permission and with written reference to the source.

Au moment de la remise à l'imprimeur, toutes les informations et figures se rapportant à cette machine correspondaient à l'état actuel des connaissances.

Sous réserve de modifications techniques!

Aucune reproduction, polycopie ou traduction - même par extraits - des listes de pièces PFAFF ne peut être effectuée, à condition d'en indiquer l'origine, sans notre autorisation expresse.

Todas las informaciones e ilustraciones de este manual estaban al día en el momento de entregarse para su impresión.

¡ Salvo modificaciones técnicas!

La reimpresión, reproducción y traducción - aunque sólo sea parcial - de las listas de piezas PFAFF sólo está permitida con nuestro permiso previo e indicando la fuente.

PFAFF Industrie Maschinen GmbH

Postfach 3020

D-67653 Kaiserslautern

Königstr. 154

D-67655 Kaiserslautern

Redaktion/Illustration

Verlag Technische Dokumentation

Postfach 1106

D-77901 Lahr

	Seite Page Page Página
0 Wichtiger Hinweis	0 - 1
Important note	
Avis important	
Observación importante	
1 Vorwort	1 - 1
Foreword	
Avant-propos	
Notas preliminares	
2 Erläuterungen der Schlüsselzeichen	2 - 1
Explanation of key markings	
Explication des symboles	
Explicaciones de los signos clave	
3 Basismaschine	
Basic machine	
Machine de base	
Máquina básicas	
3.01 Gehäuseteile	3 - 1
Housing sections	
Parties du corps	
Piezas del cárter	
3.02 Kopfteile	3 - 2
Needle head parts	
Pièces de tête	
Piezas de la cabeza	
3.03 Armteile	3 - 7
Arm parts	
Pièces de bras	
Piezas del brazo	
3.04 Grundplattenteile	3 - 10
Bedplate parts	
Pièces du plateau fondamental	
Piezas del cárter	
4 Säule vollständig	4 - 1
Post assy.	
Colonne complète	
Columna completo	

		Seite Page Page Página
5	Fadenabschneid-Einrichtung (-900/56) Thread trimmer (-900/56) Coupe-fil (-900/56) Cortahilos (-900/56)	5 - 1
6	Nähfuß heben über Pedal (-910/01) Raiser presser foot via the pedal (-910/01) Relever le pied presseur en actionnant la pédale (-910/01) Elevación del prensatelas mediante pedal (-910/01)	6 - 1
7	Presserfuß-Automatik (-910/98) Automatic presser foot lifter (-910/98) Relève-pied automatique (-910/98) Alzaprensatelas (-910/98)	7 - 1
8	Verriegelungs-Einrichtung (-911/97) Backtacking mechanism (-911/97) Dispositif à points d'arrêt (-911/97) Rematador (-911/97)	8 - 1
9	Wartungseinheit (-925/03) Air filter / lubricator (-925/03) Conditionneur d'air comprimé (-925/03) Grupo acondicionador del aire comprimido (-925/03)	9 - 1
10	Einrichtung zum Nähen gewölbter Arbeitsstücke (-940/01) Equipment for sewing tubular workpieces (-940/01) Dispositif pour la couture ou le piquage d'articles bombés (-940/01) Equipo para coser piezas abombadas (-940/01)	10 - 1
11	Elektrische Ausrüstung Electrical equipment Équipement électrique Equipo eléctrico	
11.01	Bedienfeld Control panel Panneau de commande Panel de mandos	11 - 1
12	Garnrollenständer Reel stands Porte-bobines Portacarretes	12 - 1

	Seite Page Page Página
13 Einstellehren	13 - 1
Adjustment gauges	
Calibres	
Calibres de ajuste	
14 Teile zur Tischplatte	13 - 1
Parts for table top	
Pièces du plateau	
Piezas para el tablero	
15 Fadenöler	15 - 1
Thread lubricator	
Graisseur de fil	
Lubricador del hilo	
16 Keilriemen	15 - 1
V-belt	
Courroie trapézoïdale	
Correa trapezoidal	
17 Keilriemenschutz (unter der Tischplatte)	17 - 1
Belt guard (under table top)	
Garde-courroie (sous le plateau de table)	
Guardacorreas (parte inferior)	
18 Knielüfterteile	17 - 1
Knee lifter parts	
Pièces du releveur de genouillère	
Piezas del alzaprensateles por rodillera	
19 Schmiermittel-Übersicht	19 - 1
Overview of lubricants	
Tableau de lubrifiants	
Tabla de lubricantes	
20 Index (Teilenummern / Seitenzahlen)	20 - 1
Index (part numbers / page numbers)	
Index (numéros de pièces, de pages)	
Index (números de pieza / números de página)	
21 Unterklassen-Ausstattung	
Subclass parts	
Composition des sous-classes	
Composición de las subclases	

	Seite Page Page Página
21.01 Nähwerkzeuge (PFAFF 1295)	21 - 2
Gauge parts (PFAFF 1295)	
Organes de couture (PFAFF 1295)	
Organos de costura (PFAFF 1295)	
21.02 Nähwerkzeuge (PFAFF 1296)	21 - 6
Gauge parts (PFAFF 1296)	
Organes de couture (PFAFF 1296)	
Organos de costura (PFAFF 1296)	
21.03 Nähwerkzeuge (PFAFF 3713-2/01)	21 - 22
Gauge parts (PFAFF 3713-2/01)	
Organes de couture (PFAFF 3713-2/01)	
Organos de costura (PFAFF 3713-2/01)	

Achtung!



Wir machen ausdrücklich darauf aufmerksam, daß Ersatz- und Zubehörteile, die nicht von uns geliefert werden, auch nicht von uns geprüft und freigegeben sind. Der Einbau und / oder die Verwendung solcher Produkte kann daher u. Umständen konstruktiv vorgegebene Eigenschaften Ihrer Maschine negativ verändern. Für Schäden, die durch die Verwendung von Nicht-Originalteilen entstehen, übernehmen wir keine Haftung!

Caution!



We warn you expressively that spare parts and accessories that are not supplied by us are not tested and released by us. Fitting or using these products may therefore have negative influences on features that depend on the machine design. We are not liable for any damage caused by the use of non-Pfaff parts!

Attention!



Nous attirons expressément votre attention sur le fait que les pièces de rechange et accessoires qui n'ont pas été livrés par nous n'ont pas non plus été contrôlés et agréés par nous. C'est pourquoi le montage et/ou l'utilisation de telles pièces peut éventuellement entraîner l'altération des caractéristiques de construction de votre machine. Par conséquent, nous n'assumons aucune responsabilité pour les dommages causés par l'emploi de pièces qui ne sont pas d'origine!

¡Atención!



Se hace observar que en el caso de piezas de recambio y accesorios que no hayan sido suministrados por nosotros, quiere decir que non han sido sometidas por nuestra parte a un control y que no se les ha dado el visto bueno. Por esta razón, el montaje y/o empleo de tales productos puede repercutir negativamente en las características previstas en su máquina. ¡Para los daños que eventualmente pudiesen presentarse al utilizar piezas no originales, no asumimos ninguna garantía!

- Die Seriennummer der Maschine, für die diese Teileliste Gültigkeit hat, ist auf der Titelseite aufgeführt.
 - Alle Teile sind so abgebildet, wie sie in der Maschine funktionsmäßig zusammengehören.
 - Gestrichelt dargestellte Teile zeigen angrenzende Teile aus anderen Funktionsgruppen.
 - Im oberen Teil der Bildseiten befindet sich eine Gesamtansicht der Maschine .
 - Der Einbauort der dargestellten Teile wird durch eine gerasterte Fläche gekennzeichnet.
 - Einrahmungen auf den Bildseiten zeigen, aus welchen Einzelteilen sich die Gruppenteile zusammensetzen.
 - Die auf den Bildseiten verwendeten Schlüsselzeichen (; 2 ; 3 usw.) sind im Kapitel "Erläuterungen der Schlüsselzeichen" aufgelistet.
-
- The serial number of the machine to which this parts list applies is indicated on the cover page.
 - All parts are illustrated in function groups with the parts which they function together with in the machine.
 - Parts illustrated with broken lines are parts from other function groups which border on the illustrated function group.
 - The above section of the page of illustrations contains a total view of the machine. The place for the installation of the parts pictured here is marked by the grid.
 - The framed-in sections on the illustration pages show the individual parts comprising a group.
 - The key markings used on the illustrated pages (; 2 ; 3 etc.) are listed in the chapter "Explanation of key markings".
-
- Le numéro de série de la machine pour laquelle cette liste de pièces est valable est indiqué sur la première page.
 - Toutes les pièces sont représentées en fonction de leur groupement fonctionnel dans la machine.
 - Les pièces hâchurées indiquent les pièces limitrophes de groupes de fonctions différents.
 - La partie supérieure des pages de figures comprend une présentation globale de la machine. L'emplacement des pièces représentées est signalé par quadrillages.
 - Les parties encadrées sur les pages à illustrations représentent les pièces individuelles formant groupe.
 - Vous trouverez au chapitre "Explication des symboles" une liste des symboles utilisés sur les pages de figures (; 2 ; 3 etc.)
-
- El número de serie de la máquina para la cual tiene validez esta lista de piezas va indicado en la página de título.
 - Odas las piezas están ilustradas tal como aparecen en la máquina para su funcionamiento.
 - Las piezas representadas con rayitas muestran piezas colindantes de otros grupos de funciones.
 - En la parte superior de las páginas ilustradas se puede ver una vista en conjunto de la máquina.
 - El lugar de montaje de la pieza representada va caracterizada mediante una superficie reticulada.
 - Los recuadros en las páginas ilustradas indican las piezas individuales de que se componen los grupos.
 - Los signos clave (; 2 ; 3 etc.) empleados en las páginas con ilustraciones van listados en el capítulo "Explicaciones de los signos clave".

- []** **Unterklassenabhängig, Teilenummer siehe Unterklassen-Ausstattung.**
Subclas-dependent, for part number see subclass parts listing.
Fonction de la sous-classe; pour le numéro de la pièce, voir "Equipement de sous-classes".
Dependientes de la subclase, para el número de pieza véase "Dotación de subclases".
- B** **Maschinen-Ausstattung für mittlere Materialien.**
Model B for sewing medium-weight materials.
Modèle B pour la couture de matières moyennes.
Tipo B para materiales semiligeros.
- C** **Maschinen-Ausstattung für mittelschwere Materialien.**
Model C for sewing medium-heavy materials.
Modèle C pour la couture de matières mi-lourdes.
Tipo C para materiales semipesados.
- N** **Stichlänge 6,0 mm.**
Stitch length 6.0 mm.
Longeur du point 6,0 mm.
Largo de puntada 6,0 mm.
- P** **Teile zum Hüpftransport.**
Components of four-motion drop feed.
Pièces de l'entraînement par griffe sautillante.
Piezas del transportador inferior a cuatro tiempos.
- 3** **Geklebt**
Part cemented
Pièce collée
Pieza pegada
- 5** **Nähmuster bzw. Material einsenden.**
Submit sewing sample or material.
Joindre échantillons de couture ou matières.
Enviense muestras de costura.
- 6** **Nadeldicke und Spitzenform bei Bestellung angeben.**
Needle size and style of point to be stated on order.
Préciser la grosseur de l'aiguille et la forme de la pointe à la commande.
Grosor de aguja y forma de la punta, indíquese en los pedidos.
- 10** **Nadelabstand**
Needle gauge
Ecartement des aiguilles
Distancia entre agujas
- 27/5** **Eingeklammerte Zahl = Länge in mm.**
Number in brackets = length in mm.
Chiffre entre parenthèses = longueur en mm
Cifra entre paréntesis = largura en mm.
- 28** **Sonderausführung**
Special version
Version spéciale
Tipo especial
- 28/8** **Sonderausführung, für leichten Stoffdrückerdruck.**
Special version, for light presser bar pressure.
Version spéciale, pour pression légère de la barre de pression.
Tipo especial, para presión ligera del prensatelas.

- 35/4** **Bei Montage bohren und verstiften.**
To be drilled and pinned after assembly.
Percer et goupiller après montage.
Deberá hacerse un taladro y colocarse un pasador antes del montaje.
- 40/2** **Tränken mit 28-011 201-44; Bestellnummer siehe Seite 19 - 1.**
Soak with 28-011 201-44; for part number see page 19 - 1.
Imbiber d'huile 28-011 201-44; n° de commande, voir page 19 - 1.
Empape con aceite 28-011 201-44; para el Número de pedido véase la página 19 - 1.
- 40/3** **Fetten mit 28-011 202-47; Bestellnummer siehe Seite 19 - 1.**
Grease with 28-011 202-47; for part number see page 19 - 1.
Graisser avec de la graisse 28-011 202-47; n° de commande, voir page 19 - 1.
Engrase con grasa 28-011 202-47; para el número de pedido véase la página 19 - 1.
- 40/4** **Fetten mit 28-011 202-43; Bestellnummer siehe Seite 19 - 1.**
Grease with 28-011 202-43; for part number see page 19 - 1.
Graisser avec de la graisse 28-011 202-43; n° de commande, voir page 19 - 1.
Engrase con grasa 28-011 202-43; para el número de pedido véase la página 19 - 1.
- 40/6** **Füllen mit 28-011 202-17; Bestellnummer siehe Seite 19 - 1.**
Top up with 28-011 202-17; for part number see page 19 - 1.
Remplir de 28-011 202-17; n° de commande, voir page 19 - 1.
Rellene con 28-011 202-17; para el Número de pedido véase la página 19 - 1.
- 40/7** **Tränken mit 28-011 202-17; Bestellnummer siehe Seite 19 - 1.**
Soak with 28-011 202-17; for part number see page 19 - 1.
Imbiber d'huile 28-011 202-17; n° de commande, voir page 19 - 1.
Empape con aceite 28-011 202-17; para el Número de pedido véase la página 19 - 1.
- 40/13** **Fetten mit 28-011 202-05; Bestellnummer siehe Seite 19 - 1.**
Grease with 28-011 202-05; for part number see page 19 - 1.
Graiser avec de la graisse 28-011 202-05; n° de commande, voir page 19 - 1.
Engrase con grasa 28-011 202-05; para el Número de pedido véase la página 19 - 1.
- 60** **Wahlweise**
Optional
Au choix
Opcional
- 95/8** **X-Werte bei Bestellung angeben.**
Please state x-values on order.
Indiquer les valeurs "x" à la commande.
Indíquese en los pedidos valores "x".
- 96** **Länge angeben.**
State length.
Préciser longueur.
Indíquese la largura.

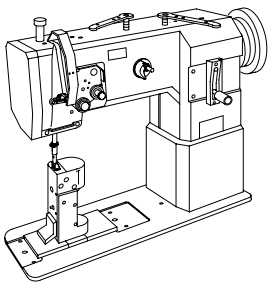

Gehäuseteile
 Housing sections PFAFF 1295 CN
 Parties du corps PFAFF 1296 BN; CN
 Piezas del cárter PFAFF 3713-2/01 CN

3.01

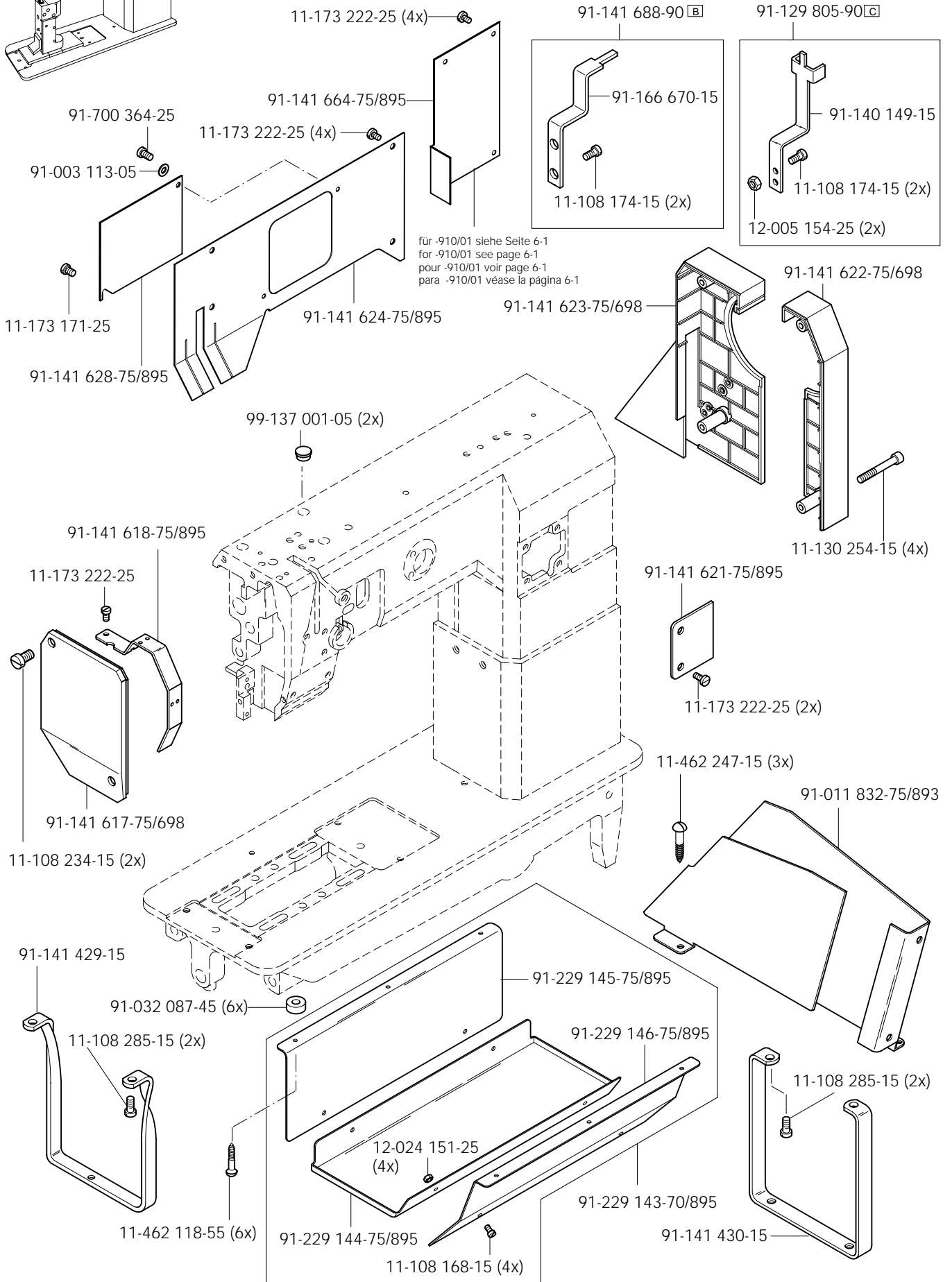

3.02

Kopfteile
Needle head parts
Pièces de tête
Piezas de la cabeza

PFAFF 1295 CN
PFAFF 1296 BN; CN
PFAFF 3713-2/01 CN

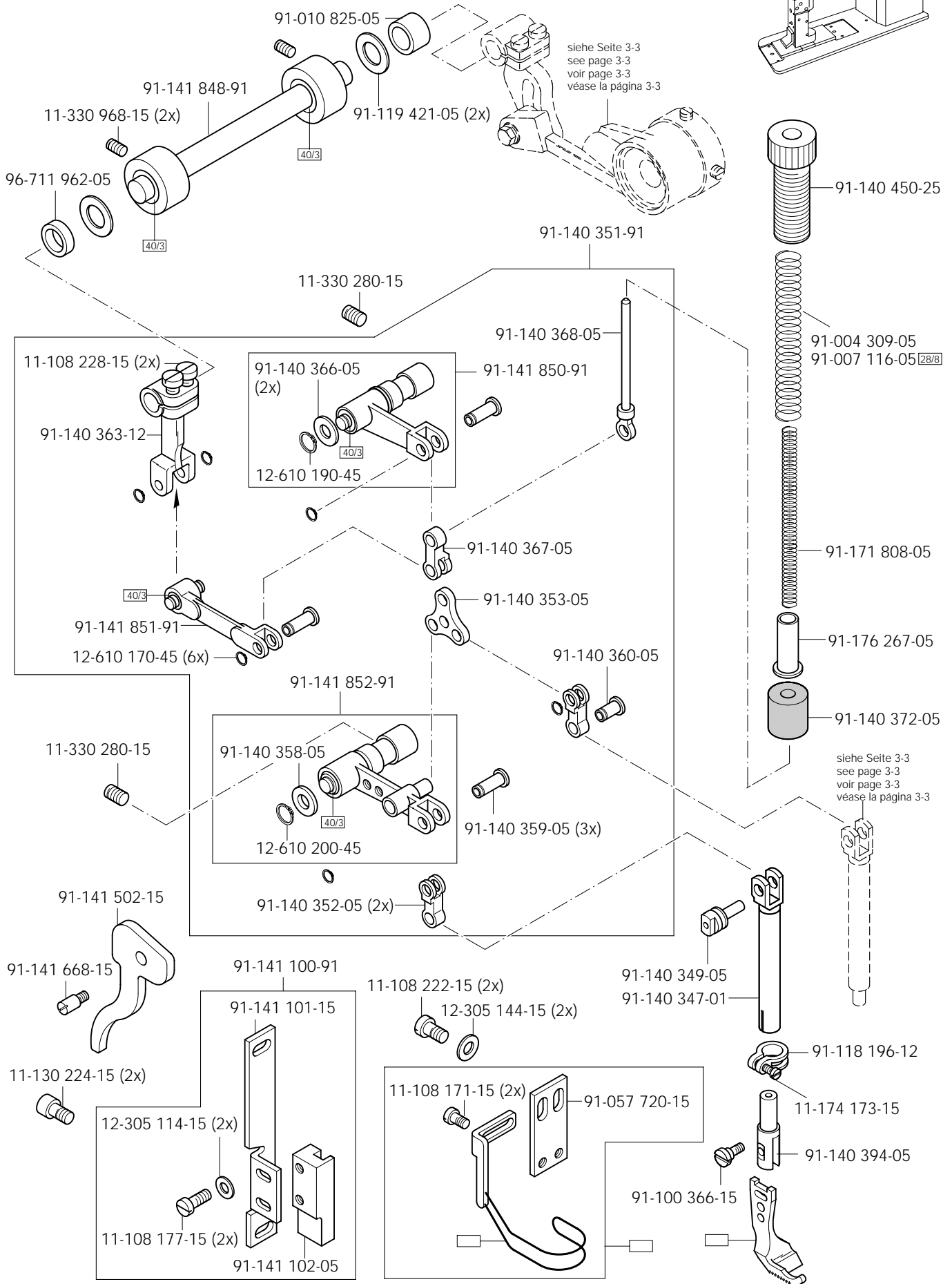
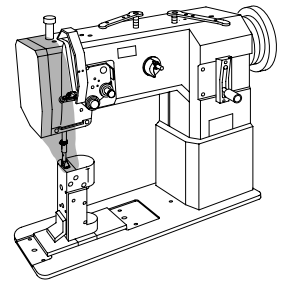

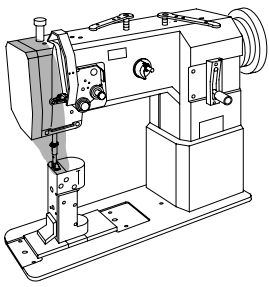

Kopfteile

Needle head parts

Pièces de tête

Piezas de la cabeza

PFAFF 1295 CN

PFAFF 1296 BN; CN

PFAFF 3713-2/01 CN

3.02

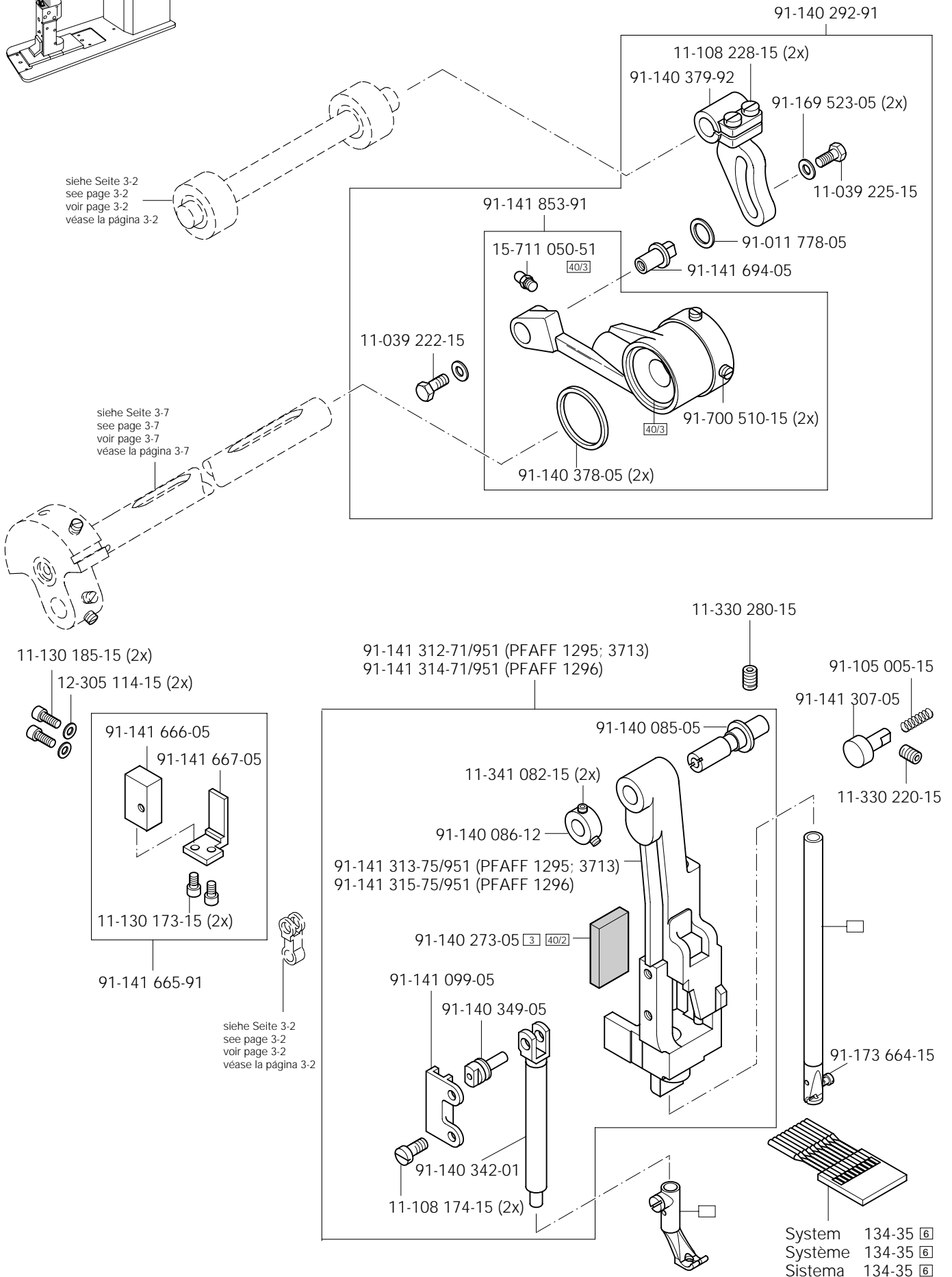

3.02

Kopfteile
 Needle head parts
 Pièces de tête
 Piezas de la cabeza

PFAFF 1295 CN
 PFAFF 1296 BN; CN
 PFAFF 3713-2/01 CN

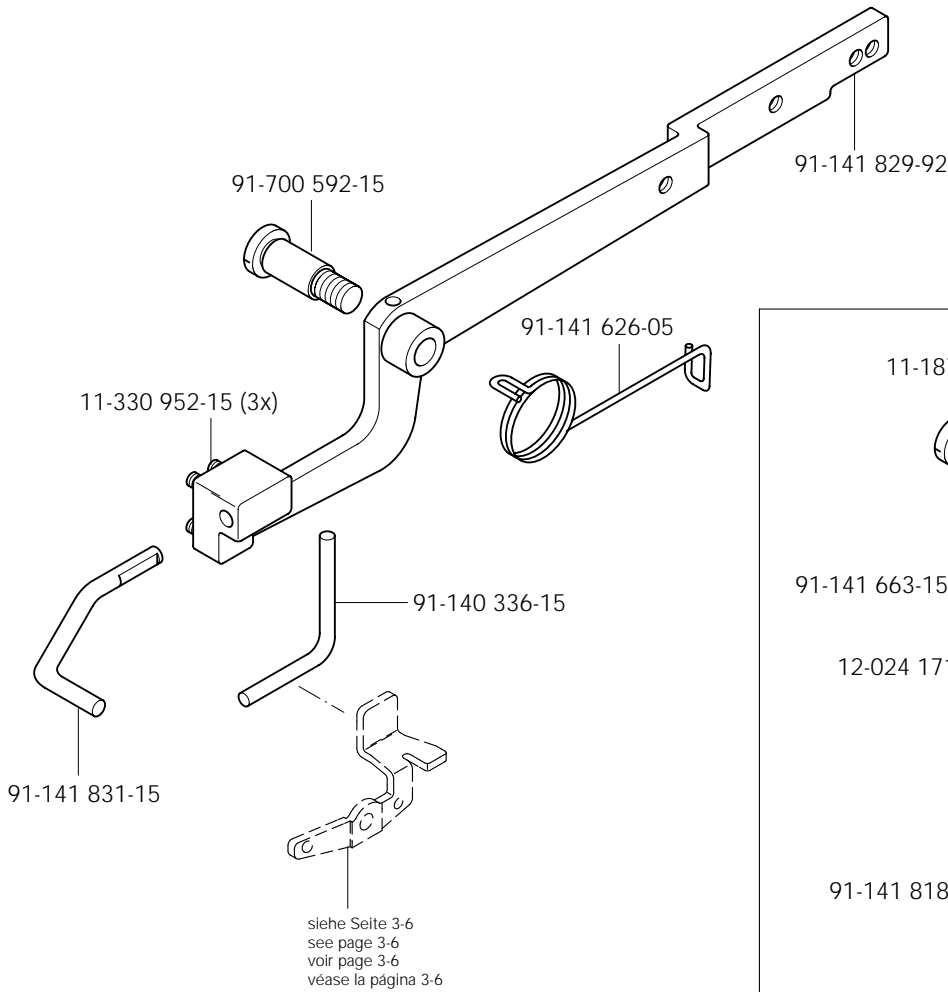
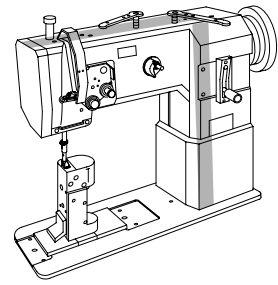

für -910/01; -910/98; -911/97; Pfaff 3713 siehe Seite 6-1; 7-1 und 8-1
 for -910/01; -910/98; -911/97; Pfaff 3713 see page 6-1; 7-1 and 8-1
 pour -910/01; -910/98; -911/97; Pfaff 3713 voir page 6-1; 7-1 et 8-1
 para -910/01; -910/98; -911/97; Pfaff 3713 véase la página 6-1; 7-1 y 8-1

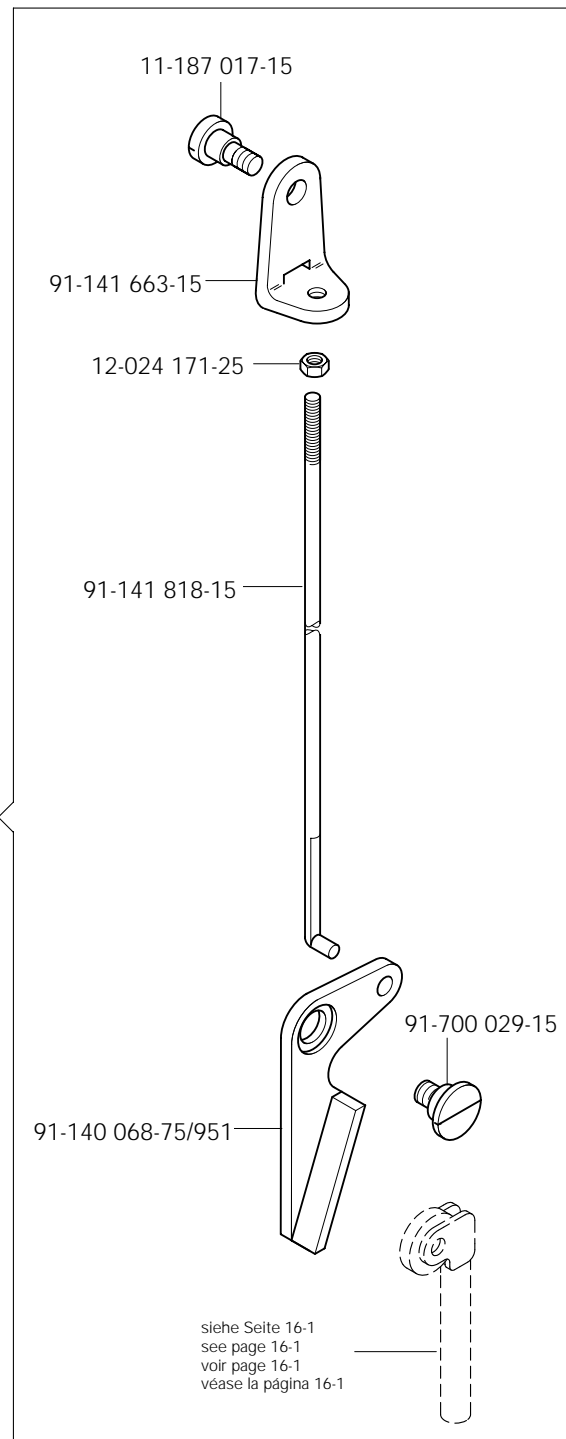

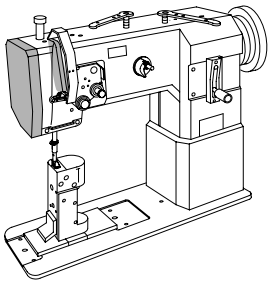

Kopfteile

Needle head parts

PFAFF 1295 CN

Pièces de tête

PFAFF 1296 BN; CN

Piezas de la cabeza

PFAFF 3713-2/01 CN

3.02

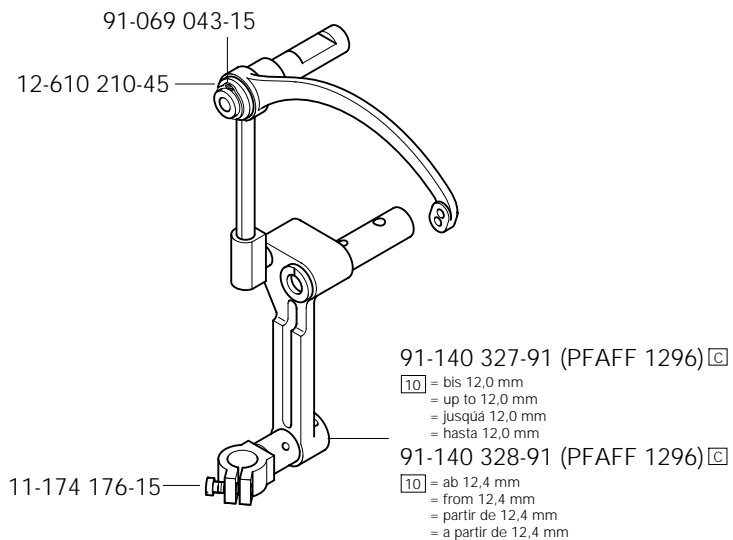
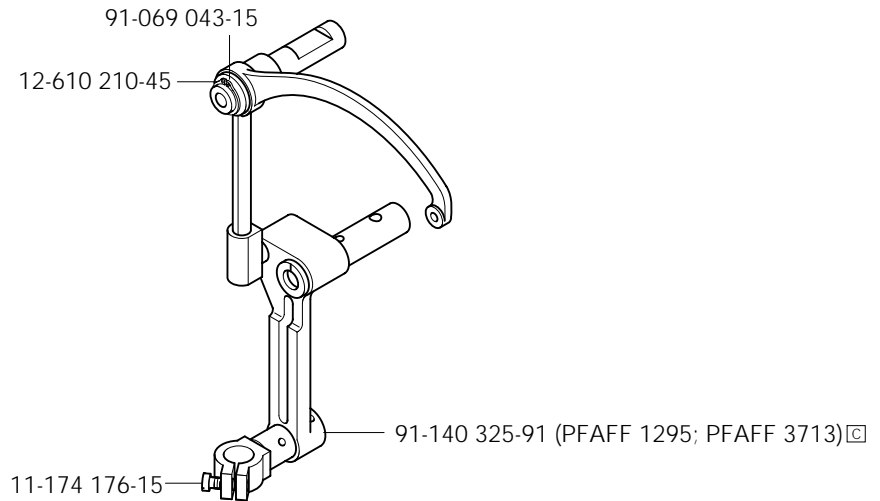
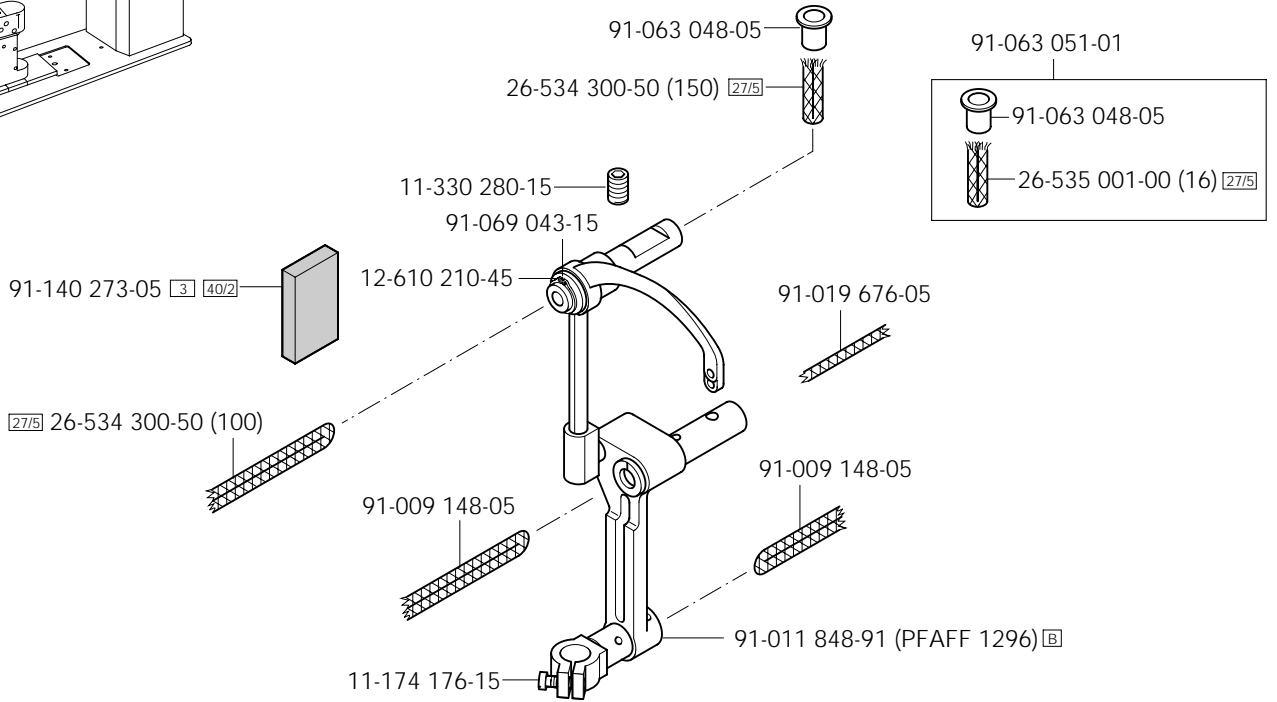

3.02

Kopfteile
Needle head parts
Pièces de tête
Piezas de la cabeza

PFAFF 1295 CN
PFAFF 1296 BN; CN
PFAFF 3713-2/01 CN

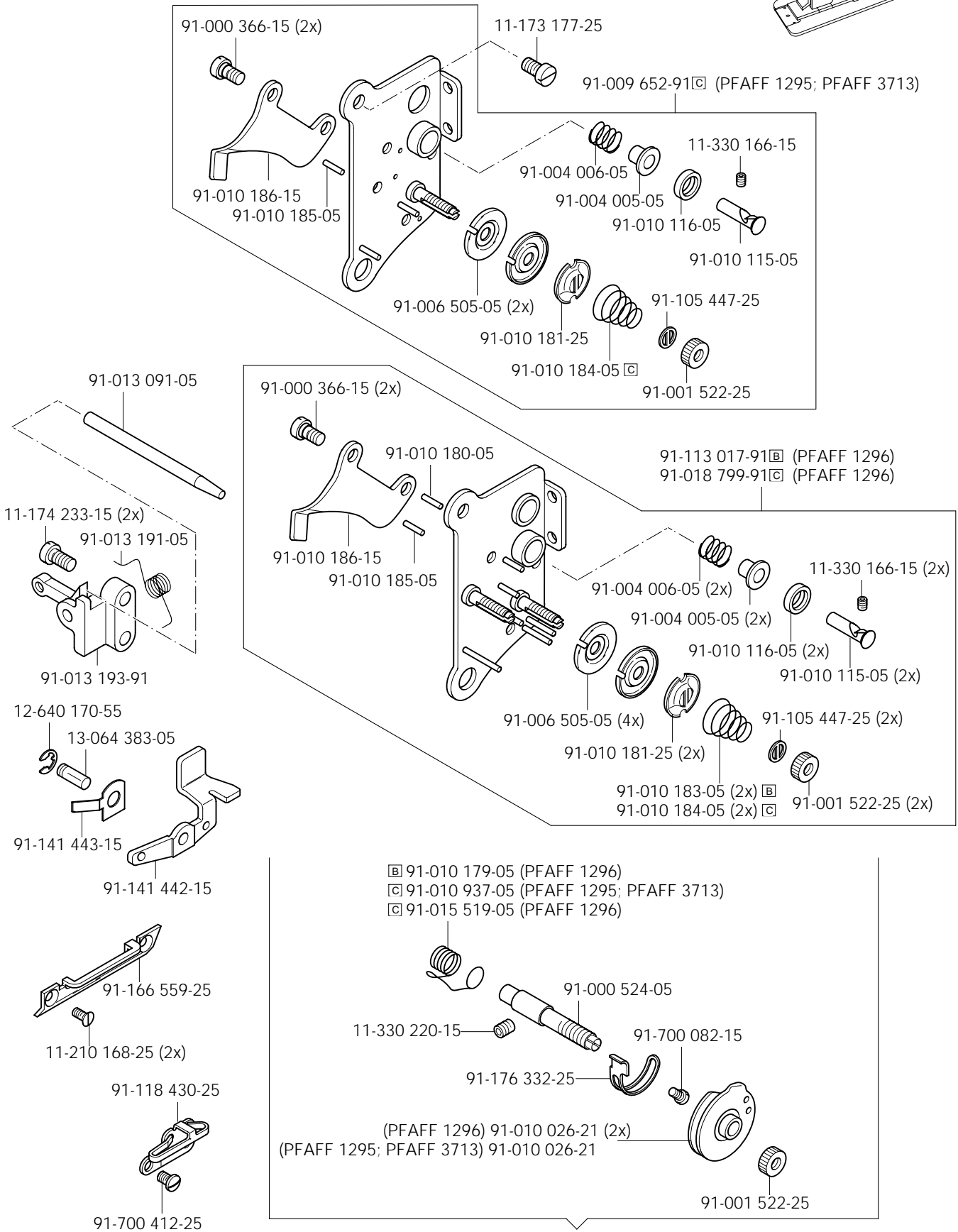
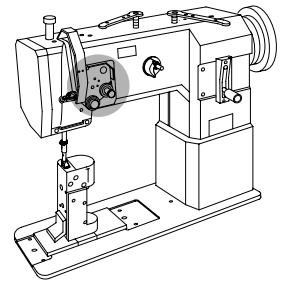

für -900/56 siehe Seite 5-1
for -900/56 see Seite 5-1
pour -900/56 voir Seite 5-1
para -900/56 véase la página 5-1

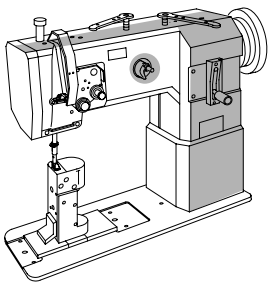

Armteile
 Arm parts PFAFF 1295 CN
 Pièces de bras PFAFF 1296 BN; CN
 Piezas del brazo PFAFF 3713-2/01 CN

3.03

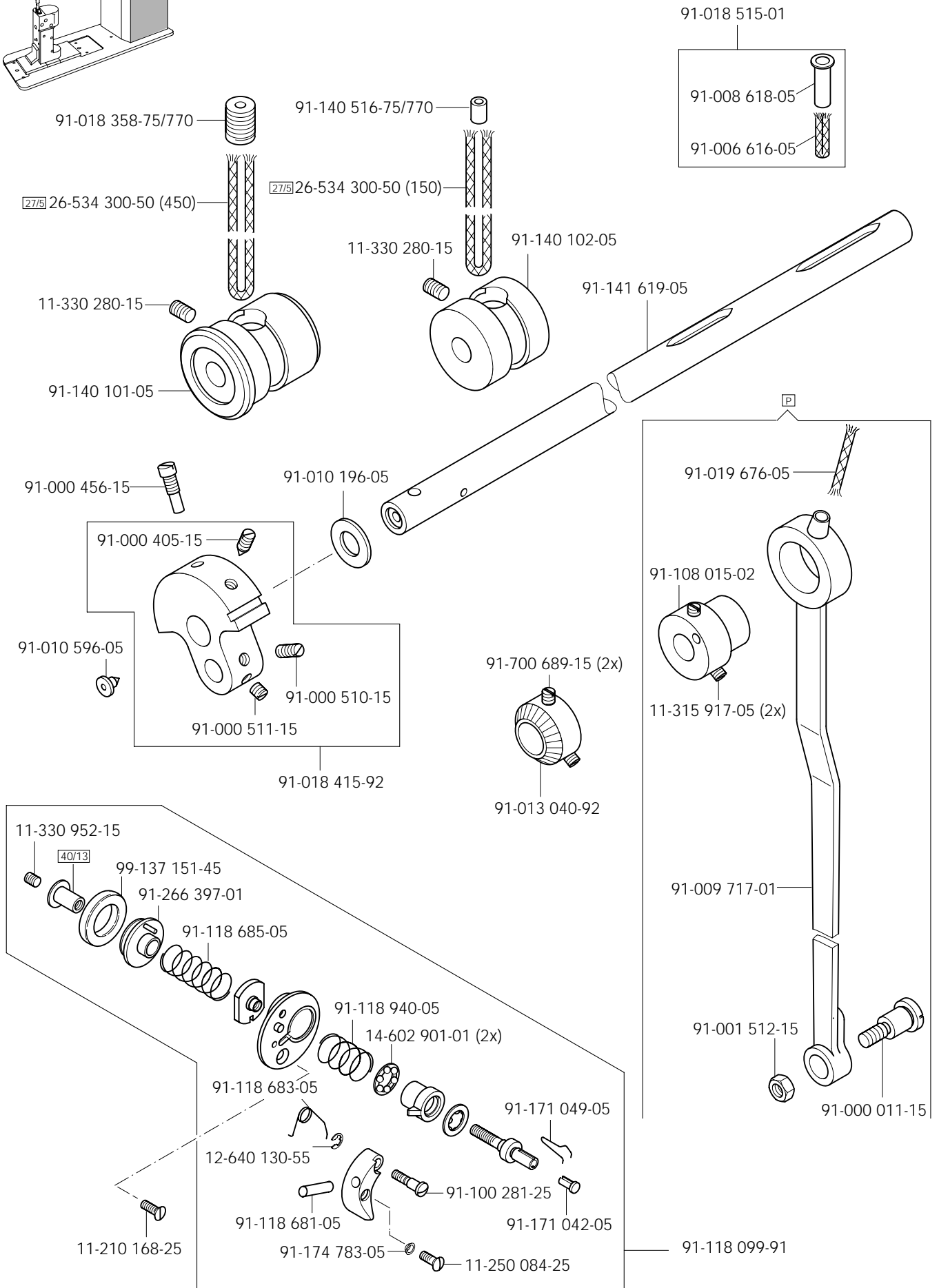

3.03

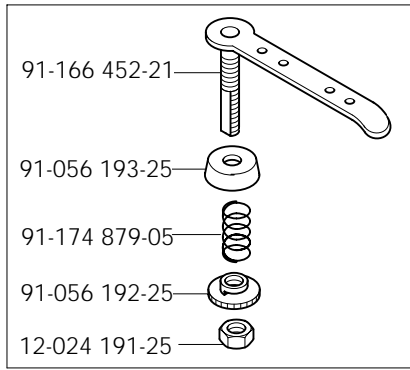
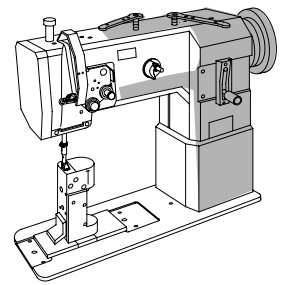

Armteile
 Arm parts
 Pièces de bras
 Piezas del brazo

PFAFF 1295 CN
 PFAFF 1296 BN; CN
 PFAFF 3713-2/01 CN

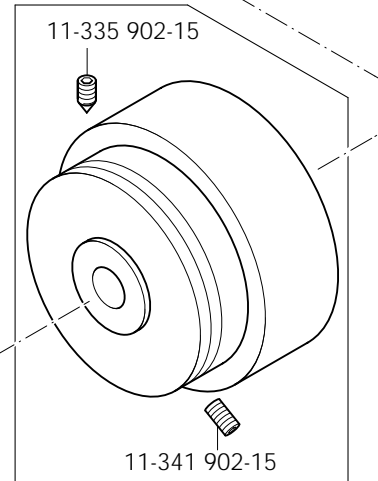
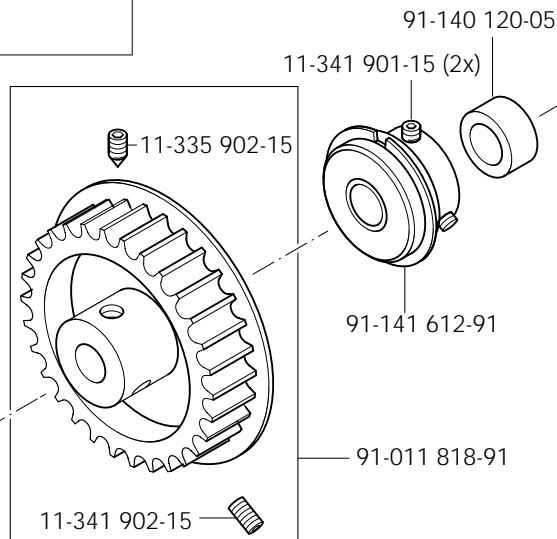
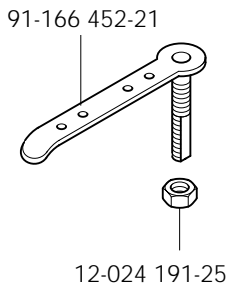
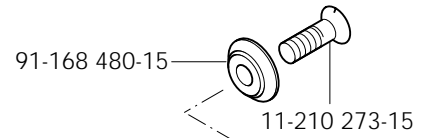

91-056 578-91



91-141 620-72/893 
 91-141 710-72/893 

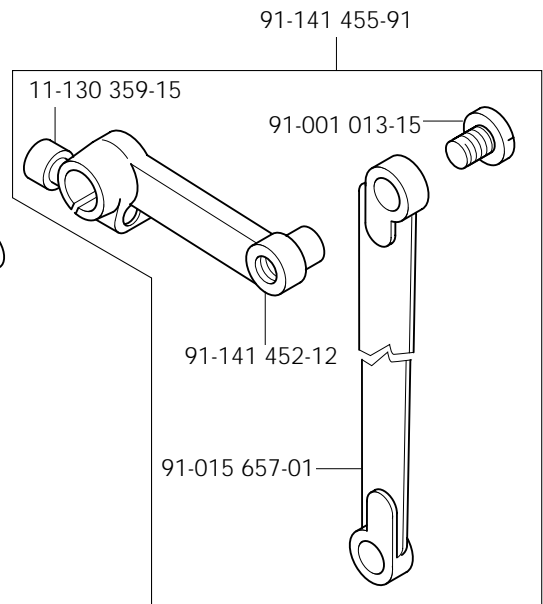
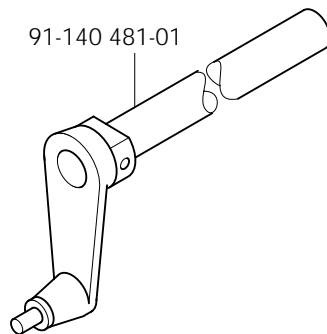
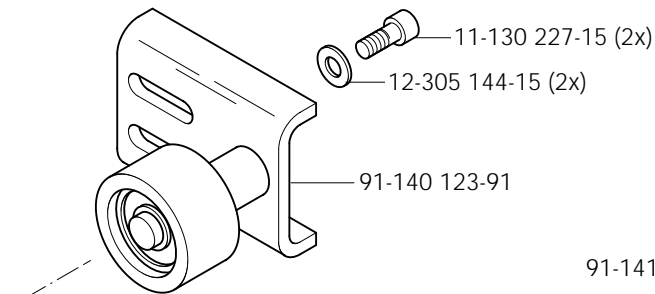
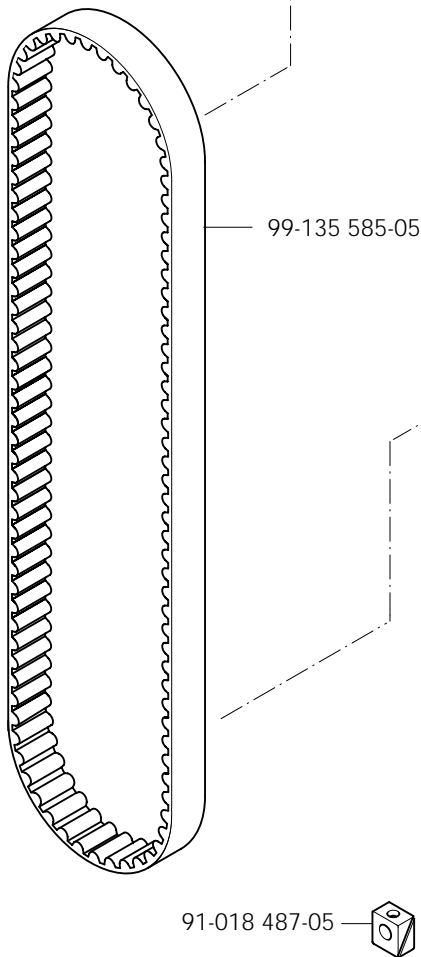

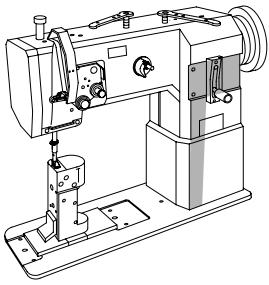

Armteile
 Arm parts PFAFF 1295 CN
 Pièces de bras PFAFF 1296 BN; CN
 Piezas del brazo PFAFF 3713-2/01 CN

3.03

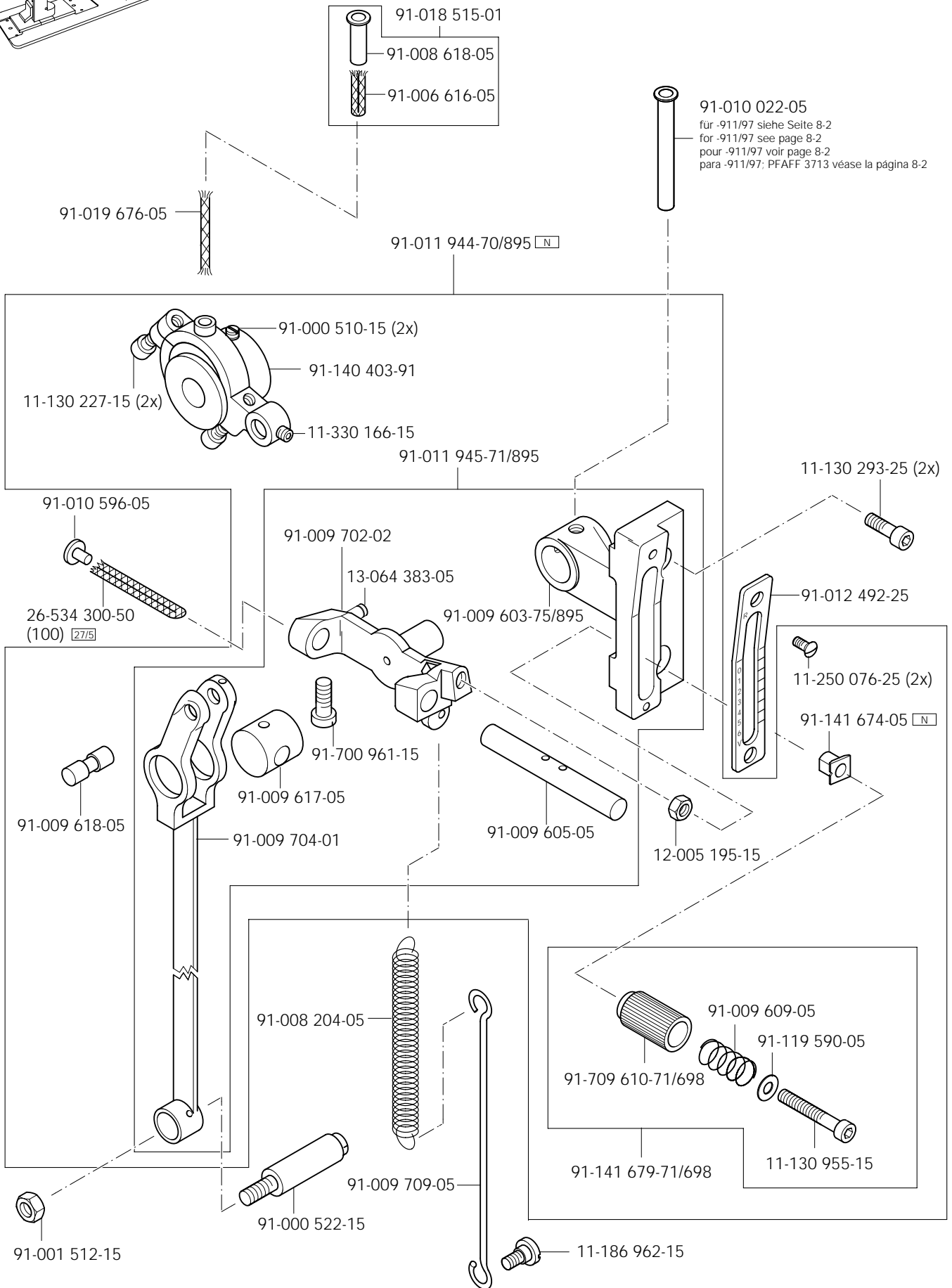

3.04

Grundplattenteile
Bedplate parts
Pièces du plateau fondamental
Piezas del cárter

PFAFF 1295 CN
PFAFF 1296 BN; CN
PFAFF 3713-2/01 CN

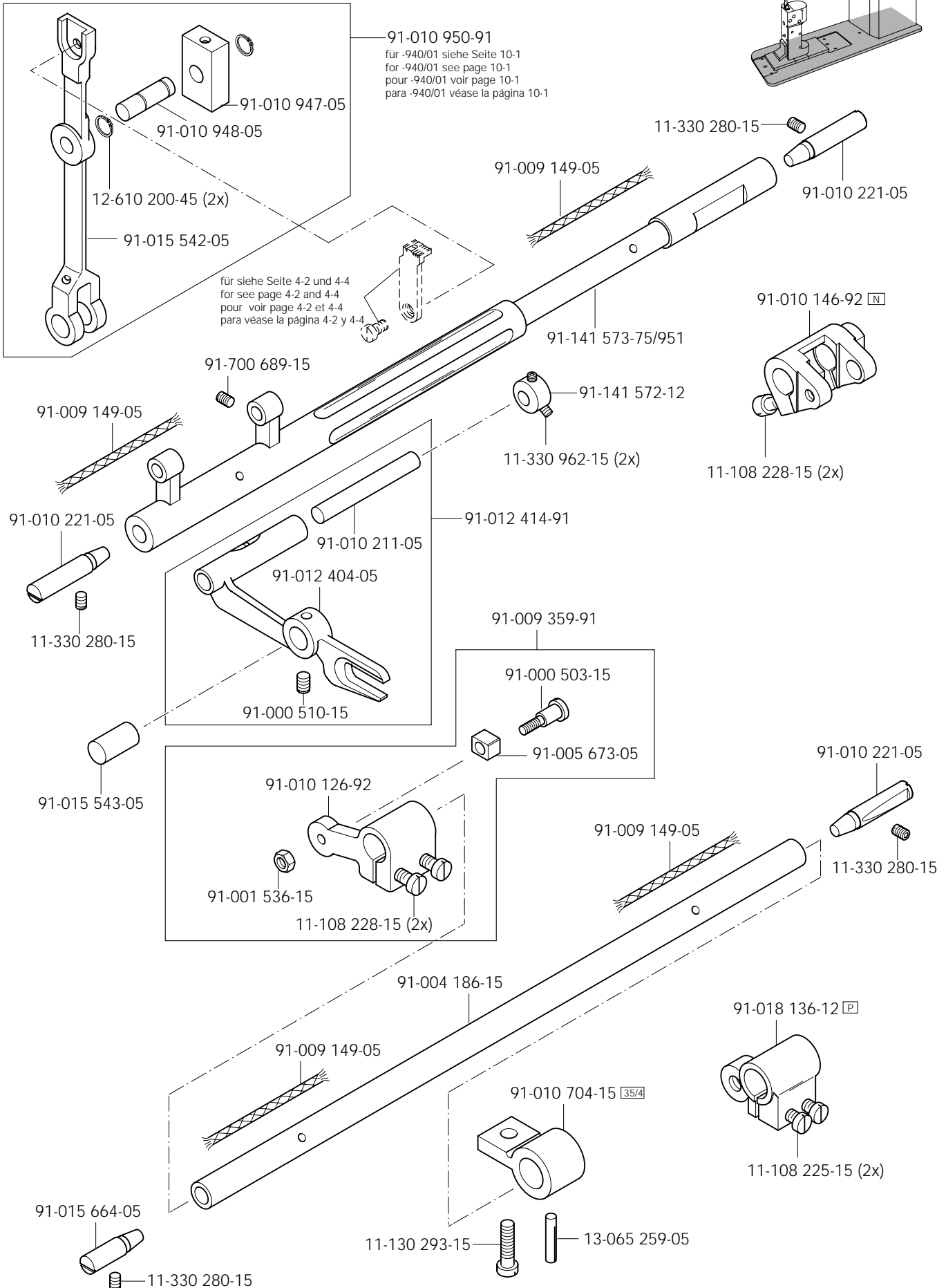
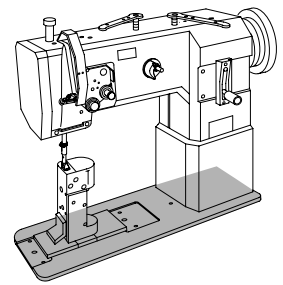

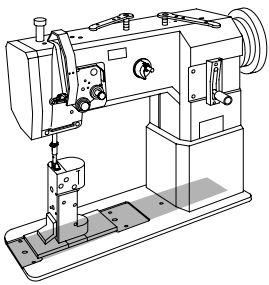

Grundplattenteile
Bedplate parts
Pièces du plateau fondamental
Piezas del cárter

PFAFF 1295 CN
PFAFF 1296 BN; CN
PFAFF 3713-2/01 CN

3.04

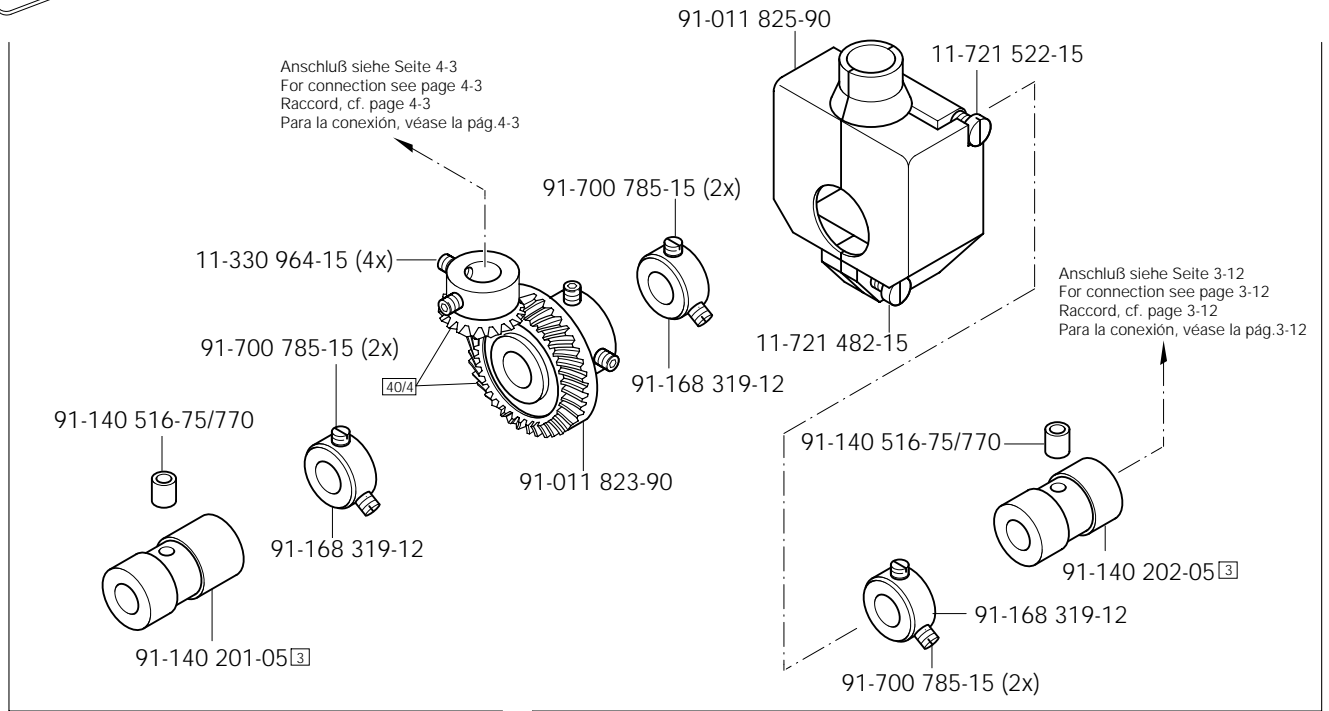

(PFAFF 1295; 3713)

(PFAFF 1296)

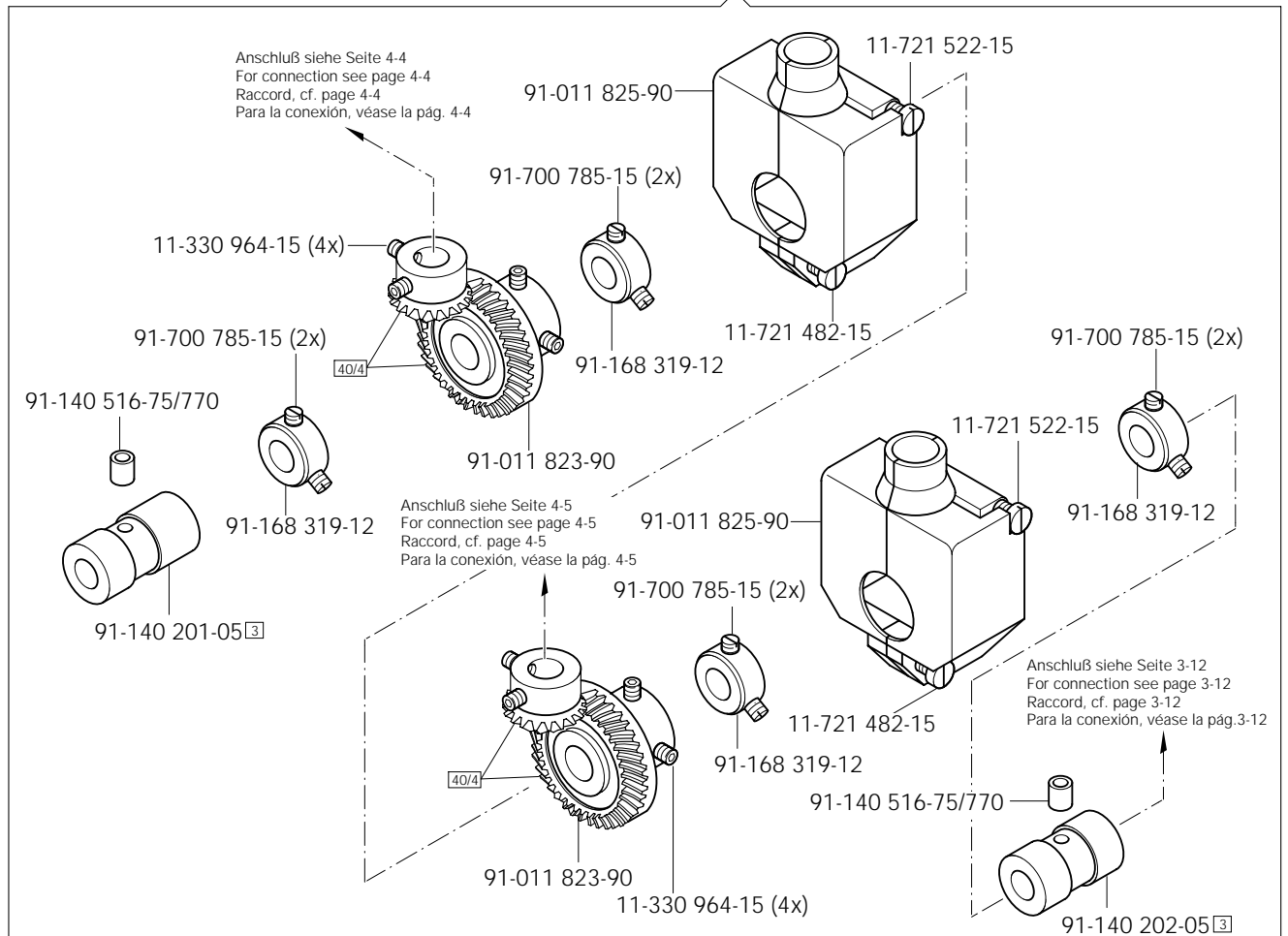

3.04

Grundplattenteile
Bedplate parts
Pièces du plateau fondamental
Piezas del cárter

PFAFF 1295 CN
PFAFF 1296 BN; CN
PFAFF 3713-2/01 CN

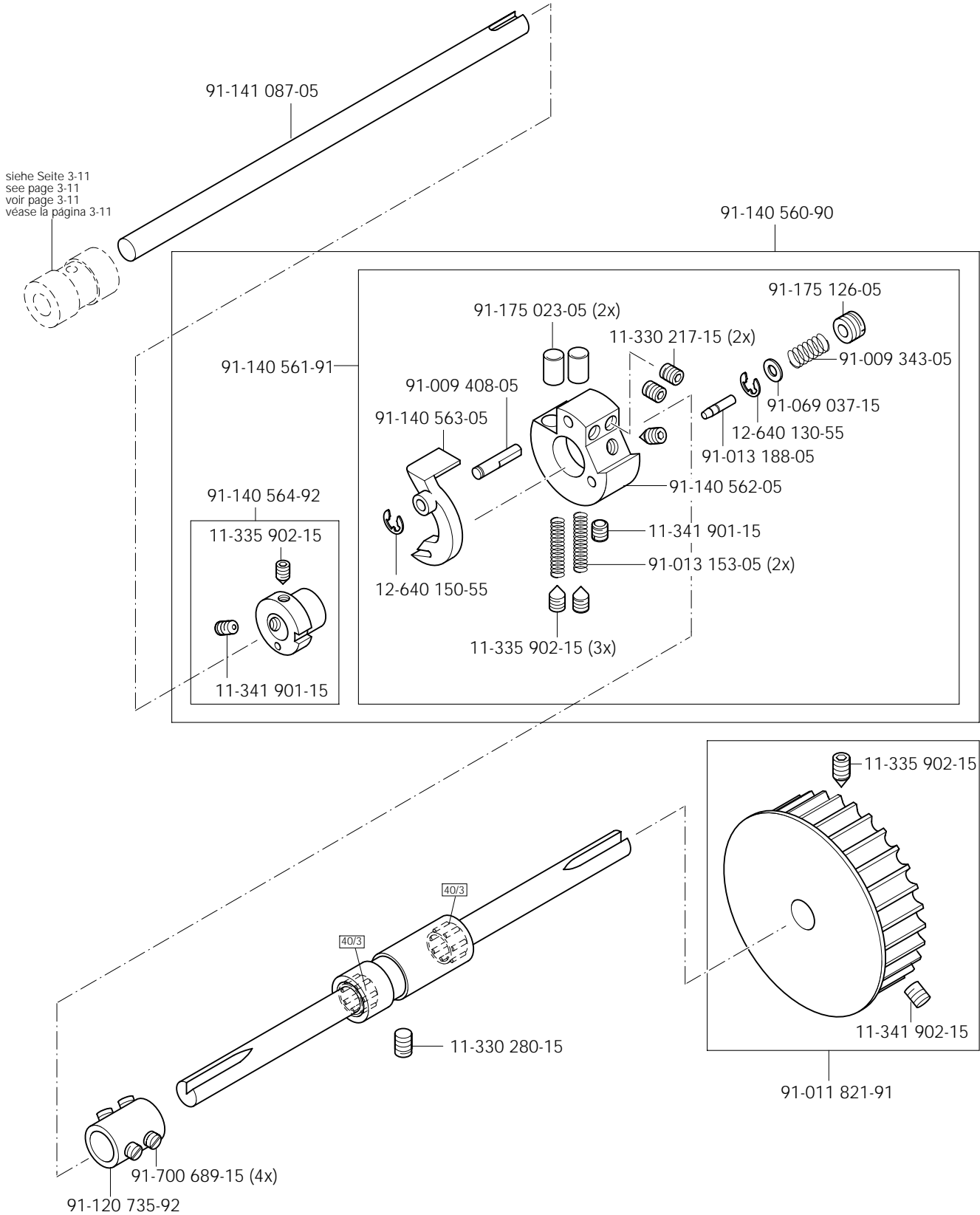
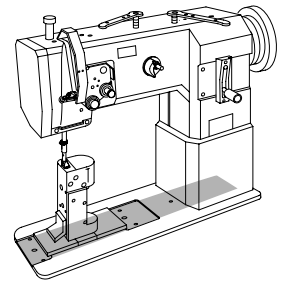

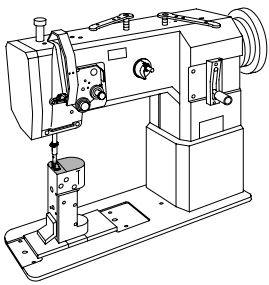

Säule vollständig
Post assy.
Colonne complète
Columna completo

PFAFF 1295 CN
PFAFF 1296 BN; CN
PFAFF 3713-2/01 CN

- 91-018 284-91 B (PFAFF 1296 -900/56)
- 91-018 285-91 C (PFAFF 1295 -900/56, 1296 -900/56; 3713)
- 91-018 340-91 C (PFAFF 1295; 1296)
- 91-018 482-91 B (PFAFF 1296)

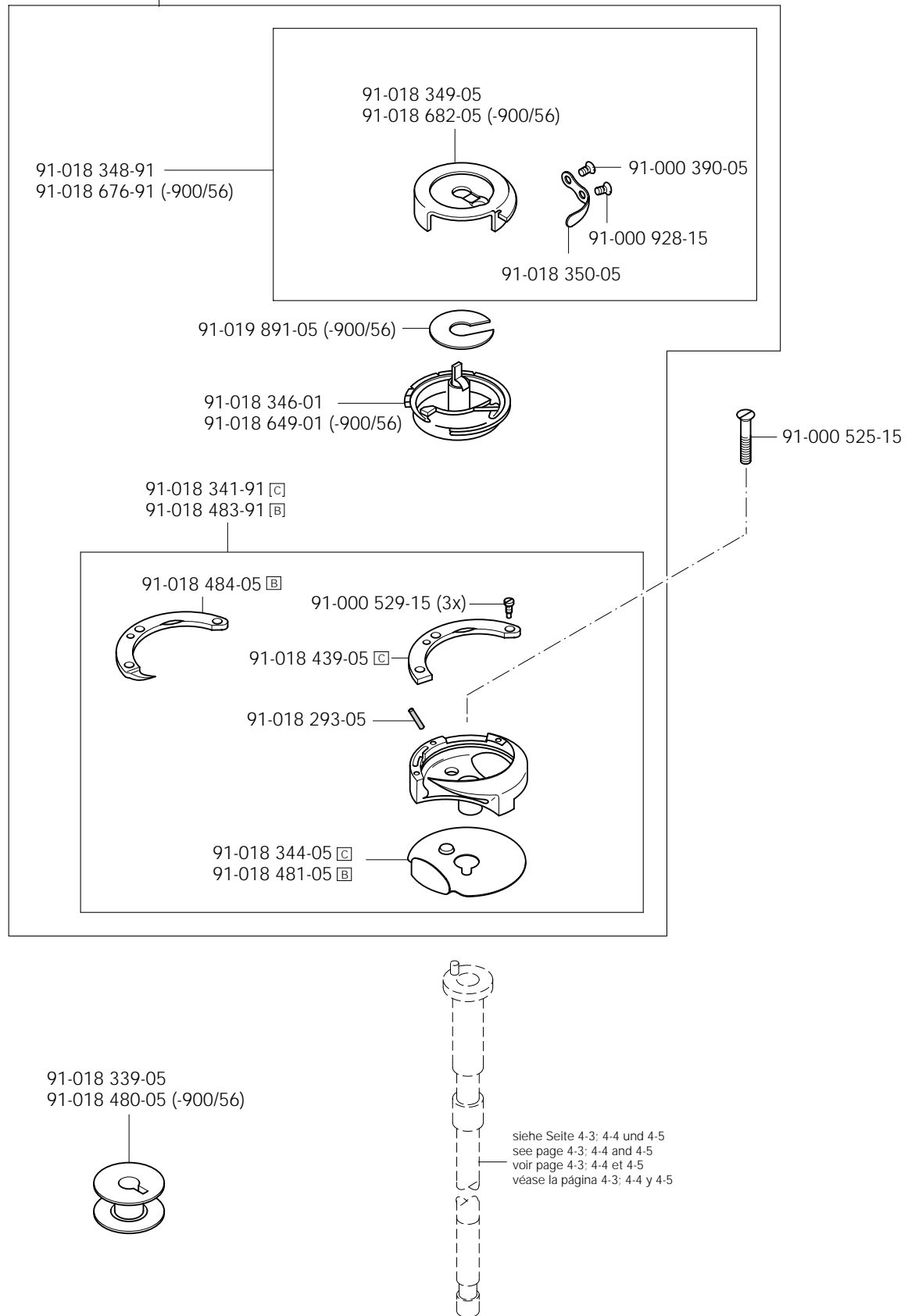

4

Säule vollständig
Post assy.
Colonne complète
Columna completo

PFAFF 1295 CN
PFAFF 3713-2/01 CN

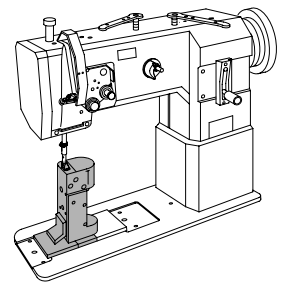

(PFAFF 1295 -900/56; 3713)

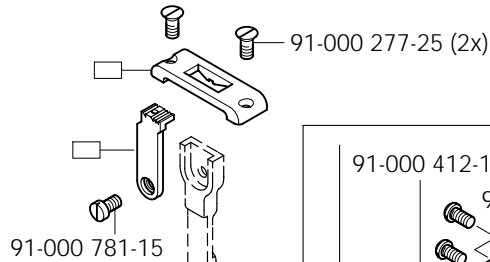
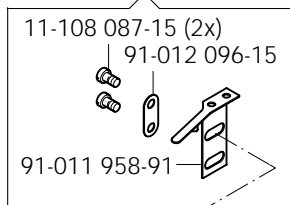

siehe Seite 3-10 und 10-1
see page 3-10 and 10-1
voir page 3-10 et 10-1
véase la página 3-10 y 10-1

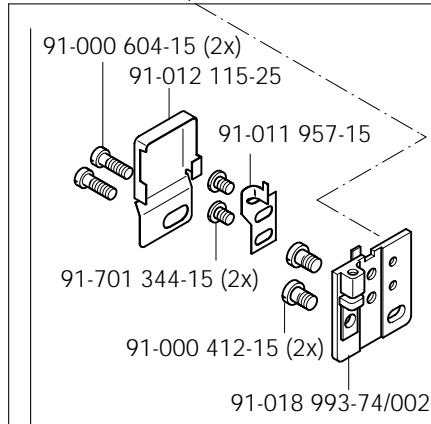

(PFAFF 1295 -900/56; 3713)

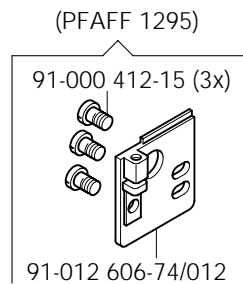

(PFAFF 1295)

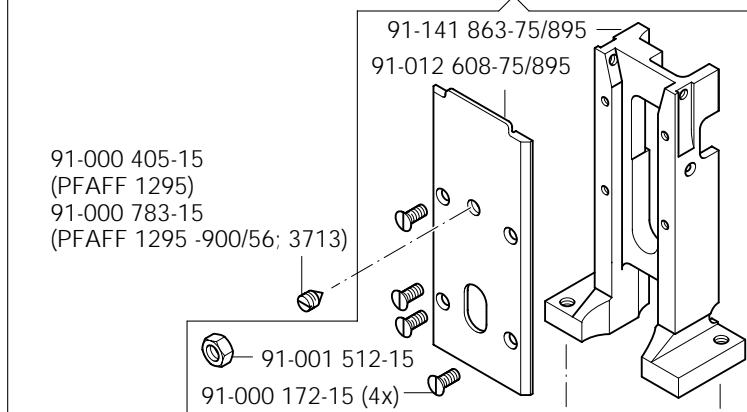
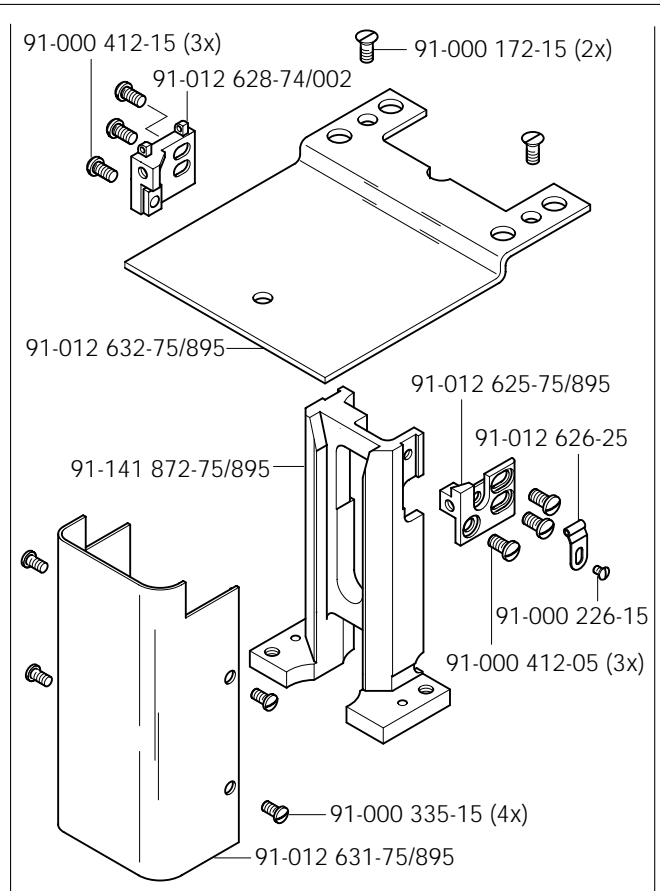

(PFAFF 1295; 1295 -900/56, 3713)

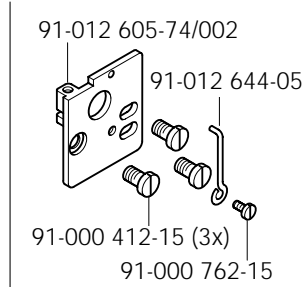

(PFAFF 1295)

(PFAFF 1295 -940/01)

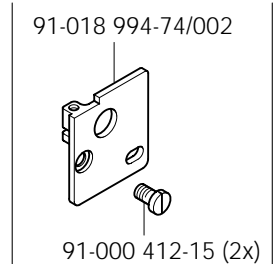

(PFAFF 1295 -900/59; 3713)

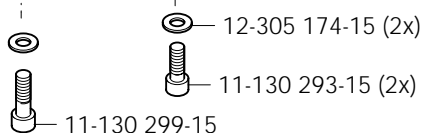
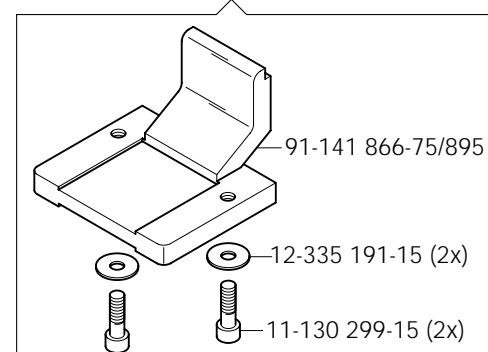

91-012 652-73/002 (PFAFF 1295 -940/01)
91-012 698-73/002 (PFAFF 1295)
91-018 269-73/002 (PFAFF 1295 -900/56; 3713)

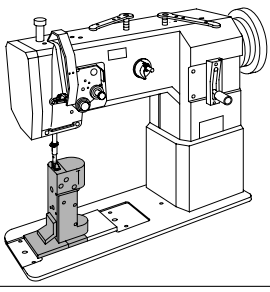

Säule vollständig
Post assy.
Colonne complète
Columna completo

PFAFF 1295 CN
PFAFF 3713-2/01 CN

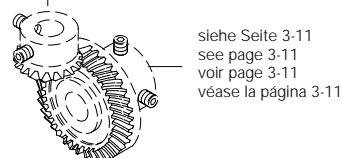
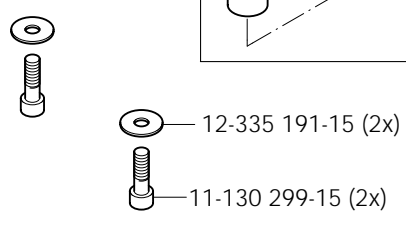
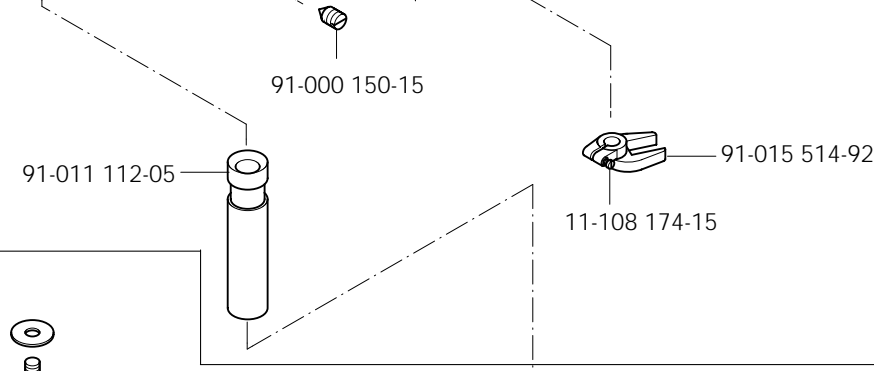
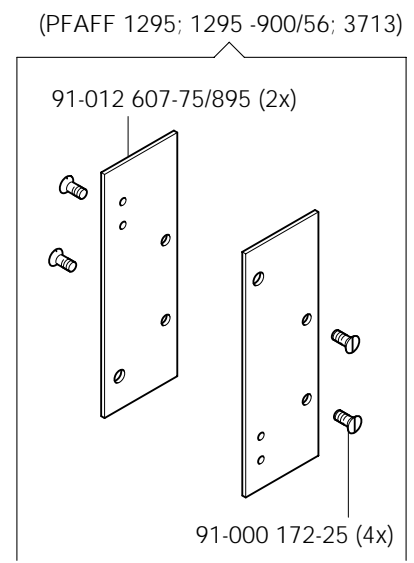
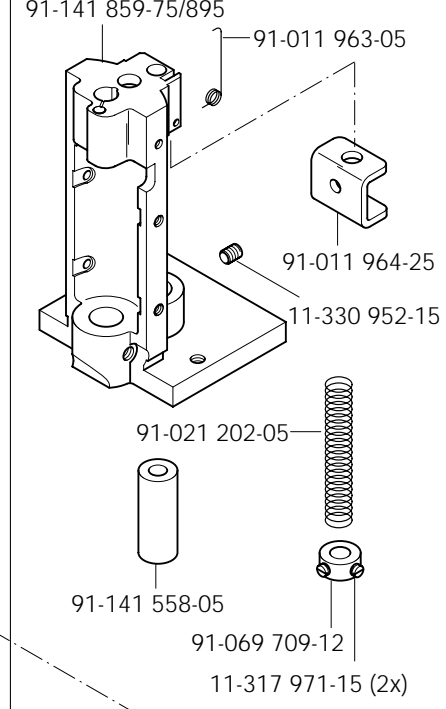
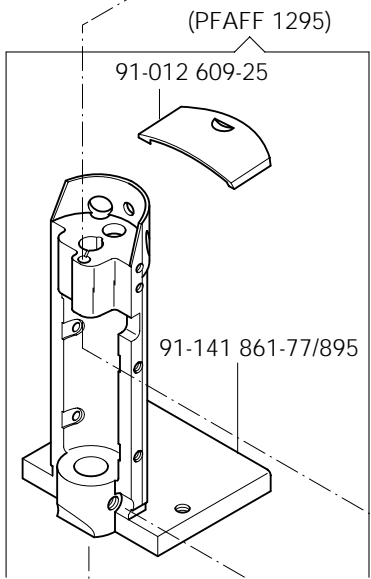
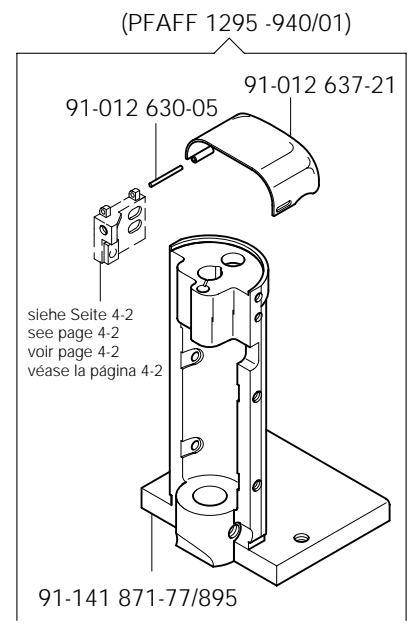
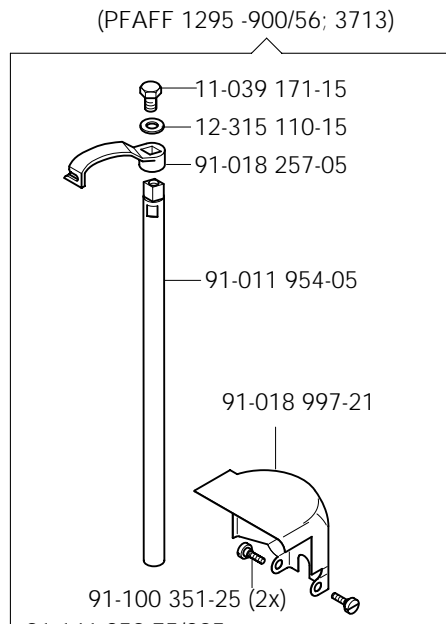
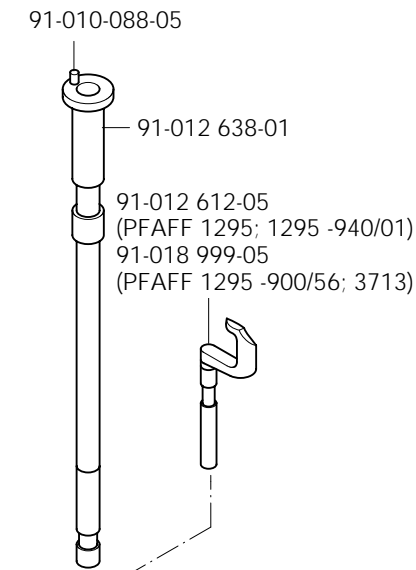

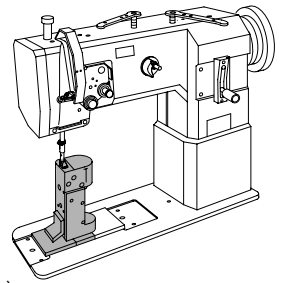

- 91-012 653-73/001 $\frac{10}{10}$ = 0,8-5,6 mm
- 91-012 653-73/002 $\frac{10}{10}$ = 6,0-10,8 mm
- 91-012 653-73/003 $\frac{10}{10}$ = 11,2-16,0 mm
- 91-012 653-73/004 $\frac{10}{10}$ = 16,4-19,2 mm
- 91-012 653-73/005 $\frac{10}{10}$ = 21,6-26,4 mm
- 91-012 653-73/006 $\frac{10}{10}$ = 26,8-31,6 mm
- 91-018 268-73/001 $\frac{10}{10}$ = 0,8-5,6 mm
- 91-018 268-73/002 $\frac{10}{10}$ = 6,0-10,8 mm
- 91-018 268-73/003 $\frac{10}{10}$ = 11,2-16,0 mm

(PFAFF 1296 -900/56)

- 11-039 171-15
- 12-315 110-15
- 91-018 257-05
- 91-011 954-05

(PFAFF 1296)

- 91-000 412-15 (5x)
- 91-012 697-74/001 $\frac{10}{10}$ = 0,8-5,6 mm
- 91-012 697-74/002 $\frac{10}{10}$ = 6,0-10,8 mm
- 91-012 697-74/003 $\frac{10}{10}$ = 11,2-16,0 mm
- 91-012 697-74/004 $\frac{10}{10}$ = 16,4-21,2 mm
- 91-012 697-74/005 $\frac{10}{10}$ = 21,6-26,4 mm
- 91-012 697-74/006 $\frac{10}{10}$ = 26,8-31,6 mm

91-000 277-25 (2x) (-900/56)

11-108 087-15 (2x)

91-012 096-15

91-000 781-15

91-011 958-91

(PFAFF 1296 -900/56)

91-000 604-15

91-011 957-15

91-000 412-15 (2x)

91-012 115-25

91-701 344-15 (2x)

91-018 992-74/001 $\frac{10}{10}$ = 0,8-5,6 mm

91-018 992-74/002 $\frac{10}{10}$ = 6,0-10,8 mm

91-018 992-74/003 $\frac{10}{10}$ = 11,2-16,0 mm

91-010-088-05

91-012 638-01

91-000 150-15

(PFAFF 1296)

91-012 609-25

91-141 861-77/895

91-018 997-21

91-100 351-25 (2x)

91-011 963-05

91-141 859-75/895

11-330 952-15

91-011 964-25

91-141 558-05

91-021 202-05

91-069 709-12

11-317 971-15 (2x)

91-015 533-05

91-012 612-05 (PFAFF 1296)

91-018 999-05 (PFAFF 1296 -900/56)

11-108 174-15

91-015 514-92

91-011 112-05

91-012 696-75/895 (2x)

91-000 486-15 (2x)

91-141 864-75/895

91-000 172-15 (4x)

- 12-335 191-15 (2x)
- 11-130 299-15 (2x)

siehe Seite 3-11
see page 3-11
voir page 3-11
véase la página 3-11

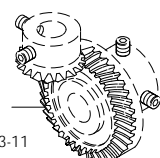

- 12-305 174-15 (2x)
- 11-130 293-15 (2x)
- 11-130 299-15

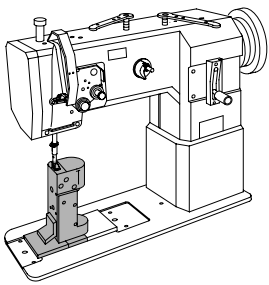

Säule vollständig
Post assy.
Colonne complète
Columna completo

PFAFF 1296 BN; CN

91-010-088-05



91-012 638-01



91-012 612-05 (PFAFF 1296)
91-018 999-05
(PFAFF 1296 -900/56)



(PFAFF 1296)

91-012 609-25



91-141 861-77/895

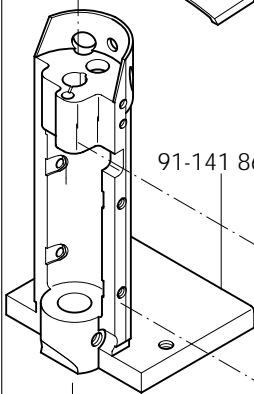

91-011 112-05

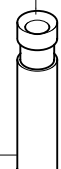

91-000 150-15



(PFAFF 1296 -900/56)

11-039 171-15



12-315 110-15



91-018 257-05

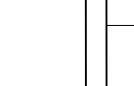

91-011 954-05

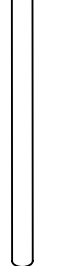

91-018 997-21

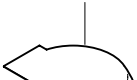

91-100 351-25 (2x)



91-141 859-75/895



91-011 963-05



91-011 964-25



11-330 952-15



91-021 202-05



91-141 558-05



91-069 709-12



11-317 971-15 (2x)



91-015 514-92

11-108 174-15



91-012 696-75/895 (2x)

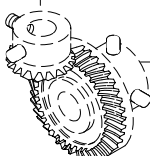

siehe Seite 3-11
see page 3-11
voir page 3-11
véase la página 3-11

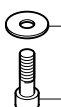
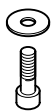

12-335 191-15 (2x)

11-130 299-15 (2x)

(PFAFF 1296)

91-012 697-74/001 $\overline{10}$ = 0,8-5,6 mm
91-012 697-74/002 $\overline{10}$ = 6,0-10,8 mm
91-012 697-74/003 $\overline{10}$ = 11,2-16,0 mm
91-012 697-74/004 $\overline{10}$ = 16,4-21,2 mm
91-012 697-74/005 $\overline{10}$ = 21,6-26,4 mm
91-012 697-74/006 $\overline{10}$ = 26,8-31,6 mm

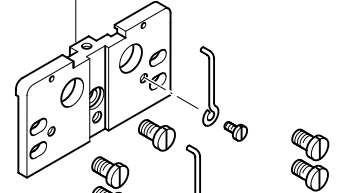

91-000 412-25 (5x)

91-012 644-05 (2x)

91-000 762-15 (2x)

(PFAFF 1296 -900/56)

91-018 992-74/001 $\overline{10}$ = 0,8-5,6 mm
91-018 992-74/002 $\overline{10}$ = 6,0-10,8 mm
91-018 992-74/003 $\overline{10}$ = 11,2-16,0 mm

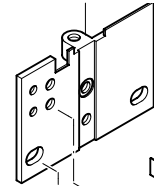

91-011 957-15

91-000 412-15 (2x)

91-701 344-15
(2x)

91-012 115-25

91-000 604-15

91-011 958-91
91-012 096-15

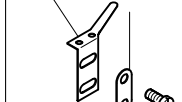

11-108 087-15 (2x)

(-900/56)

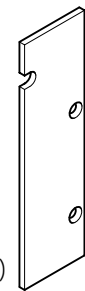
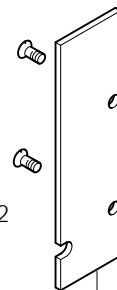

91-000 172-25 (4x)

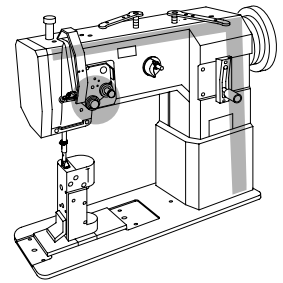

(PFAFF 1296)

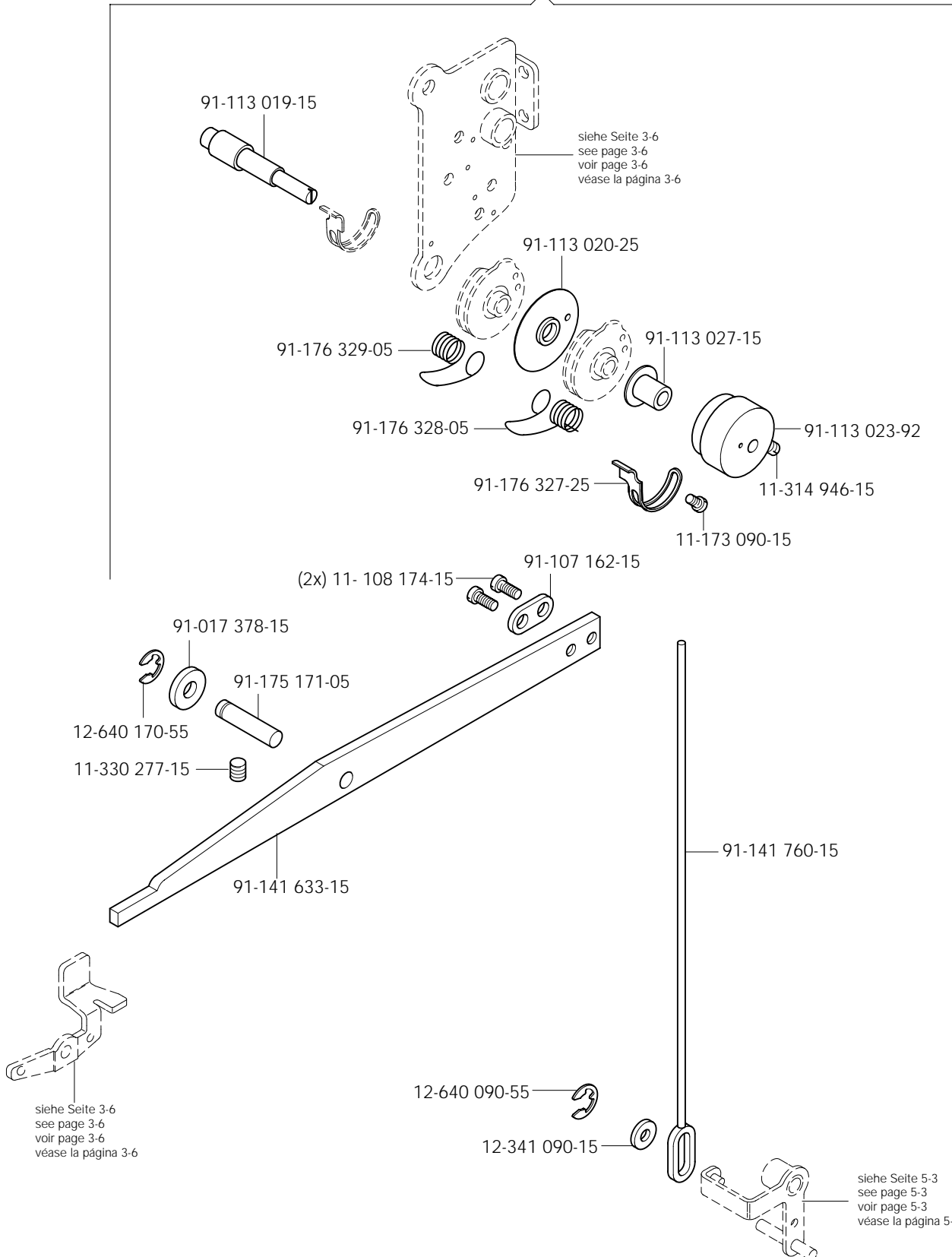

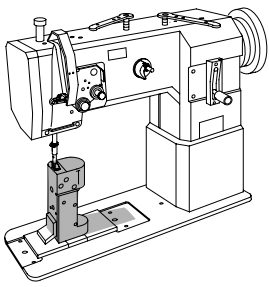

Fadenabschneid-Einrichtung (-900/56)
 Thread trimmer (-900/56)
 Coupe-fil (-900/56)
 Cortahilos (-900/56)

PFAFF 1295 CN
 PFAFF 1296 BN; CN
 PFAFF 3713-2/01 CN

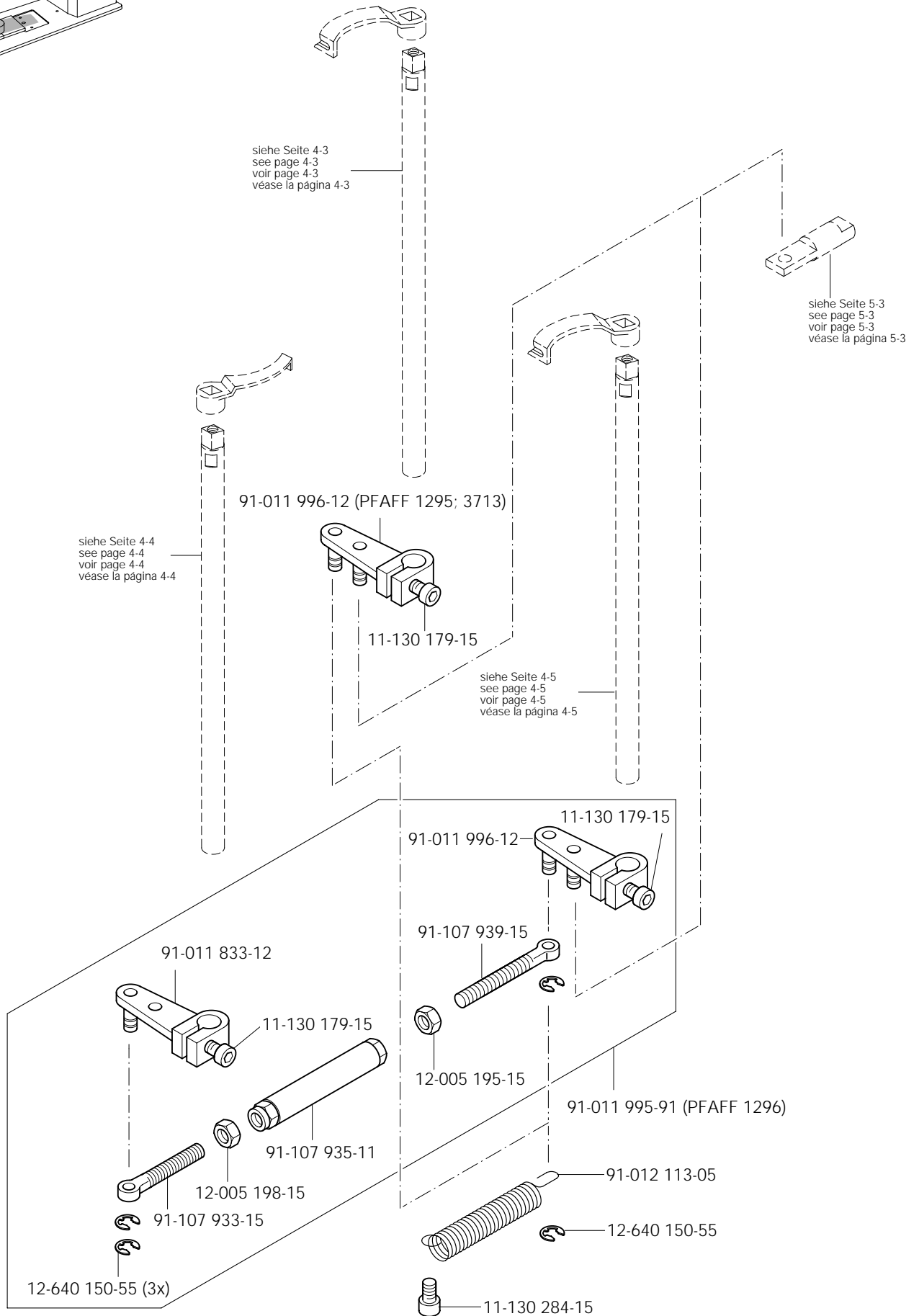

5

Fadenabschneid-Einrichtung (-900/56)
 Thread trimmer (-900/56)
 Coupe-fil (-900/56)
 Cortahilos (-900/56)

PFAFF 1295 CN
 PFAFF 1296 BN; CN
 PFAFF 3713-2/01 CN

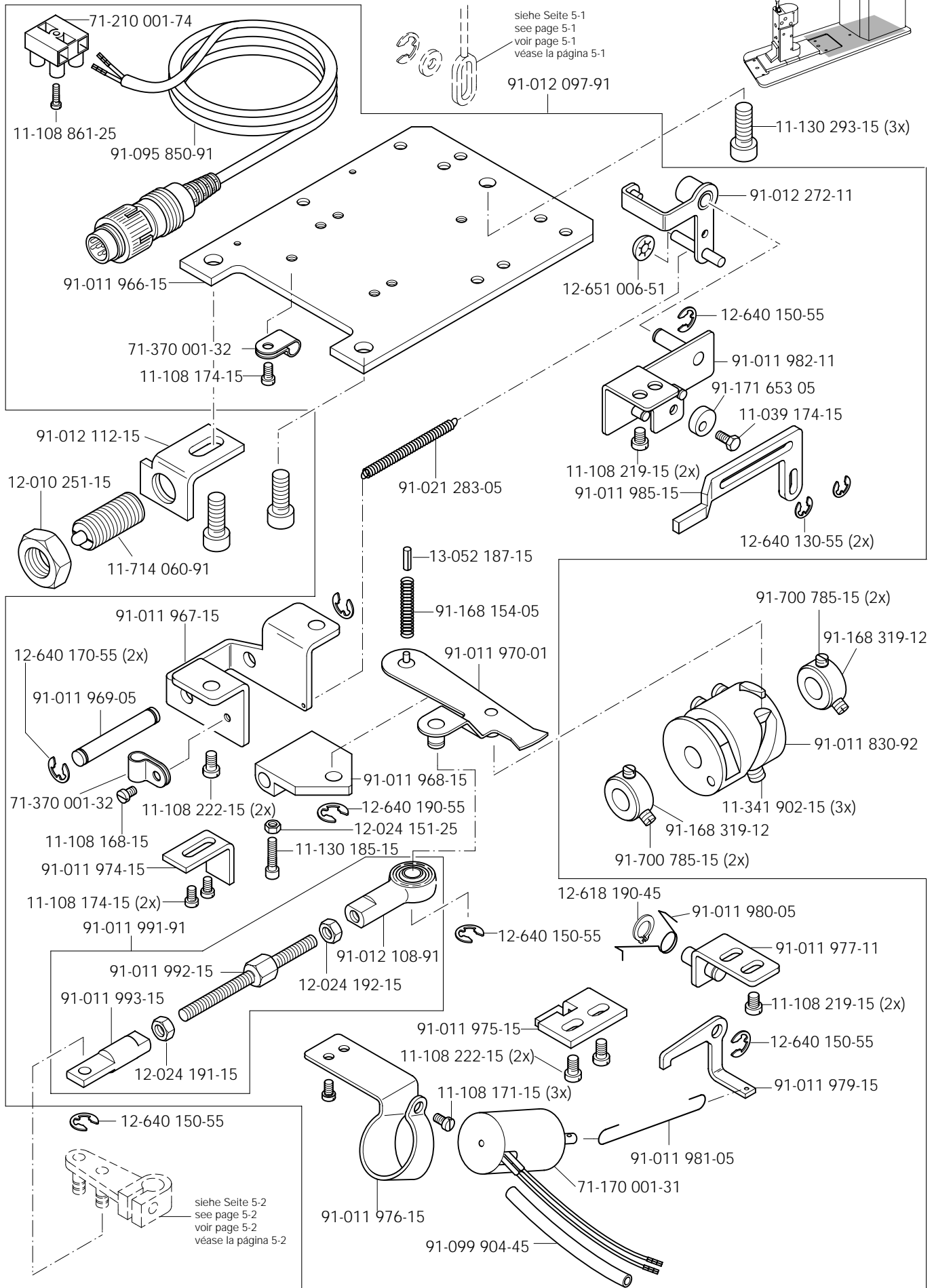
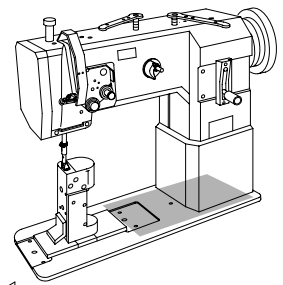

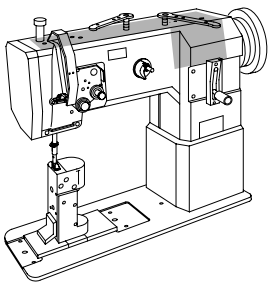

Nähfuß heben über Pedal (-910/01)

Raiser presser foot via the pedal (-910/01)

Relever le pied presseur en actionnant la pédale (-910/01) PFAFF 1295 CN

Elevación del prensatelas mediante pedal (-910/01) PFAFF 1296 BN; CN

6

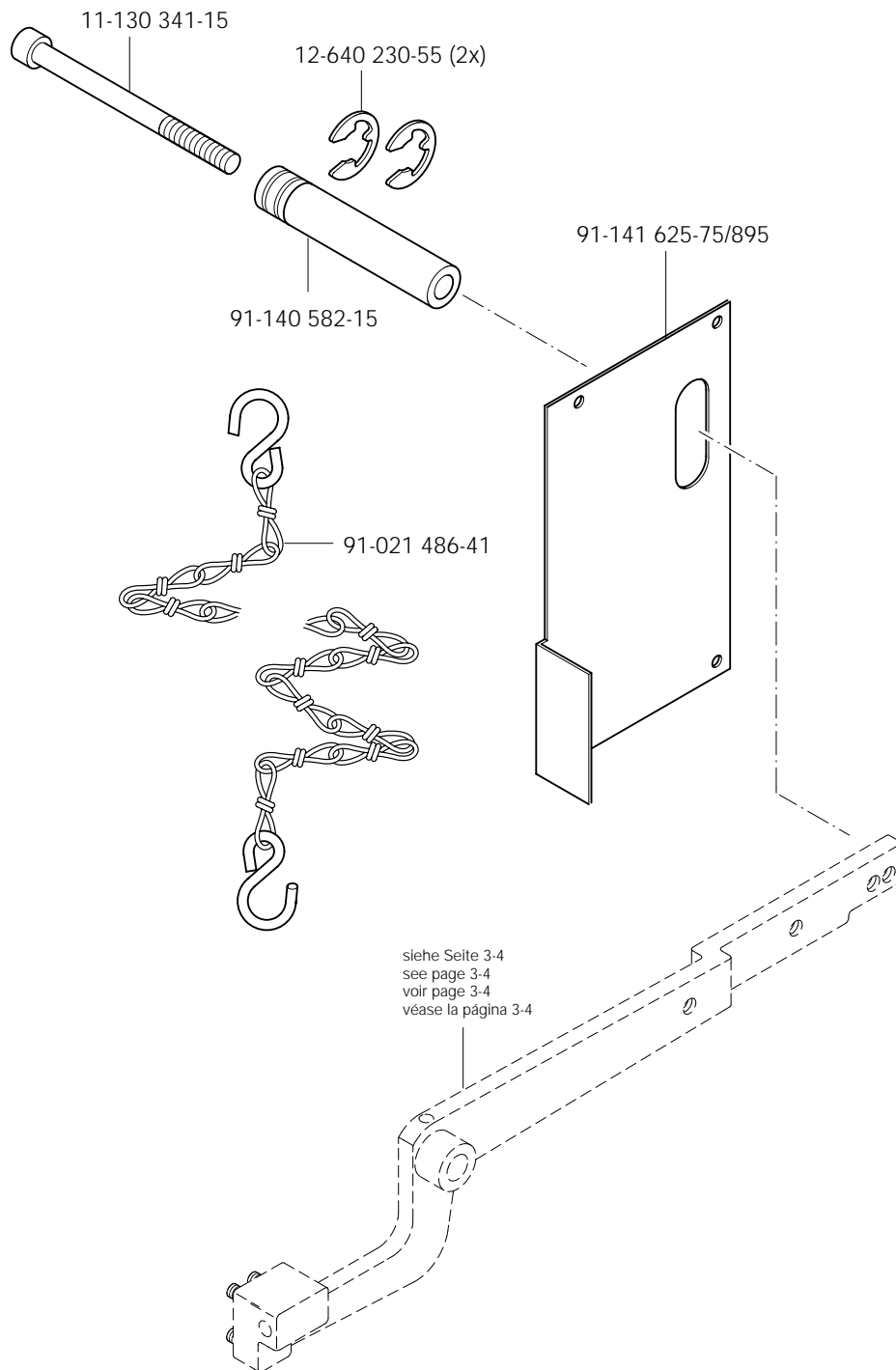

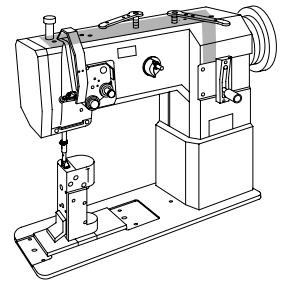

Wartungseinheit -925/03 erforderlich
 Conditioning unit -925/03 required
 Conditionneur d'air comprimé -925/03 nécessaire
 Requiere grupo acondicionador del aire comprimido -925/03

siehe Seite 3-4
 see page 3-4
 voir page 3-4
 véase la página 3-4

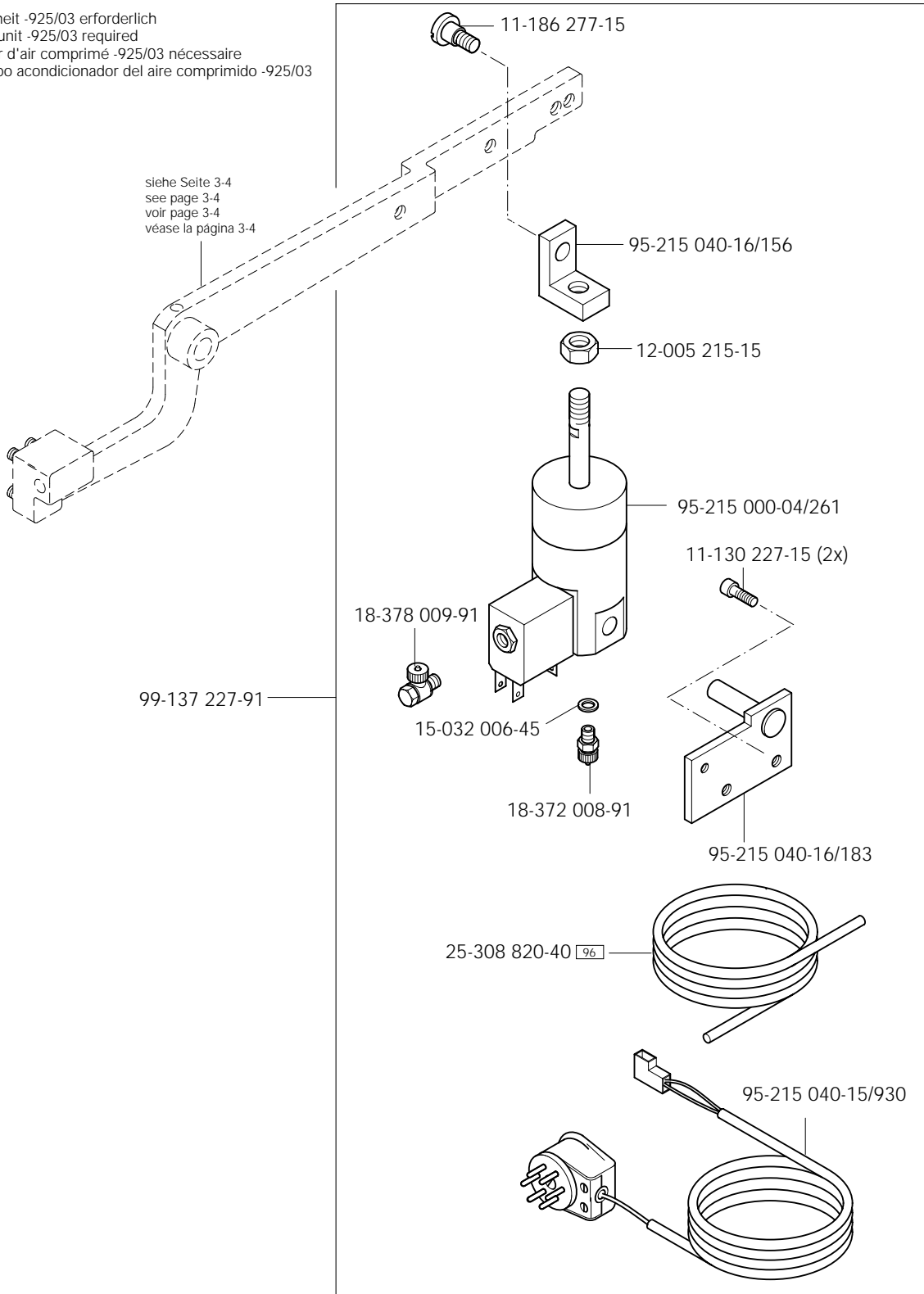

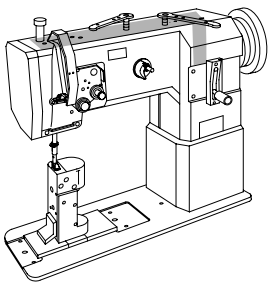

Verriegelungs-Einrichtung (-911/97)
 Backtacking mechanism (-911/97)
 Dispositif à points d'arrêt (-911/97)
 Rematador (-911/97)

PFAFF 1295 CN
 PFAFF 1296 BN; CN
 PFAFF 3713-2/01 CN

Wartungseinheit -925/03 erforderlich
 Conditioning unit -925/03 required
 Conditionneur d'air comprimé -925/03 nécessaire
 Requiere grupo acondicionador del aire comprimido -925/03

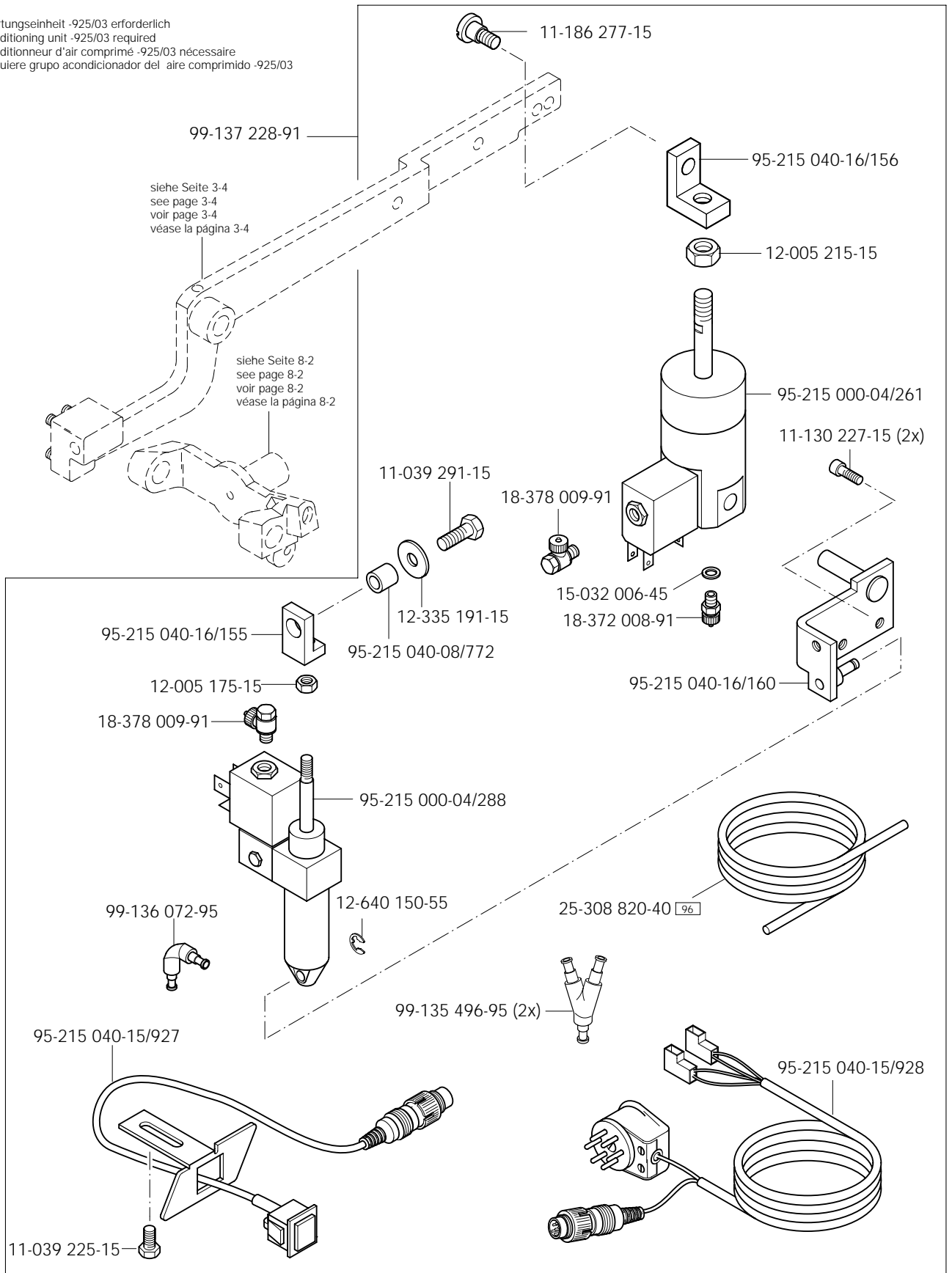

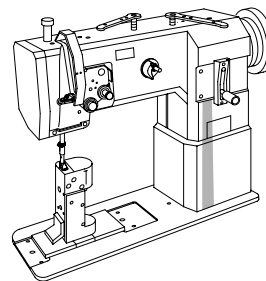

Wartungseinheit -925/03 erforderlich
 Conditioning unit -925/03 required
 Conditionneur d'air comprimé -925/03 nécessaire
 Requiere grupo acondicionador del aire comprimido -925/03

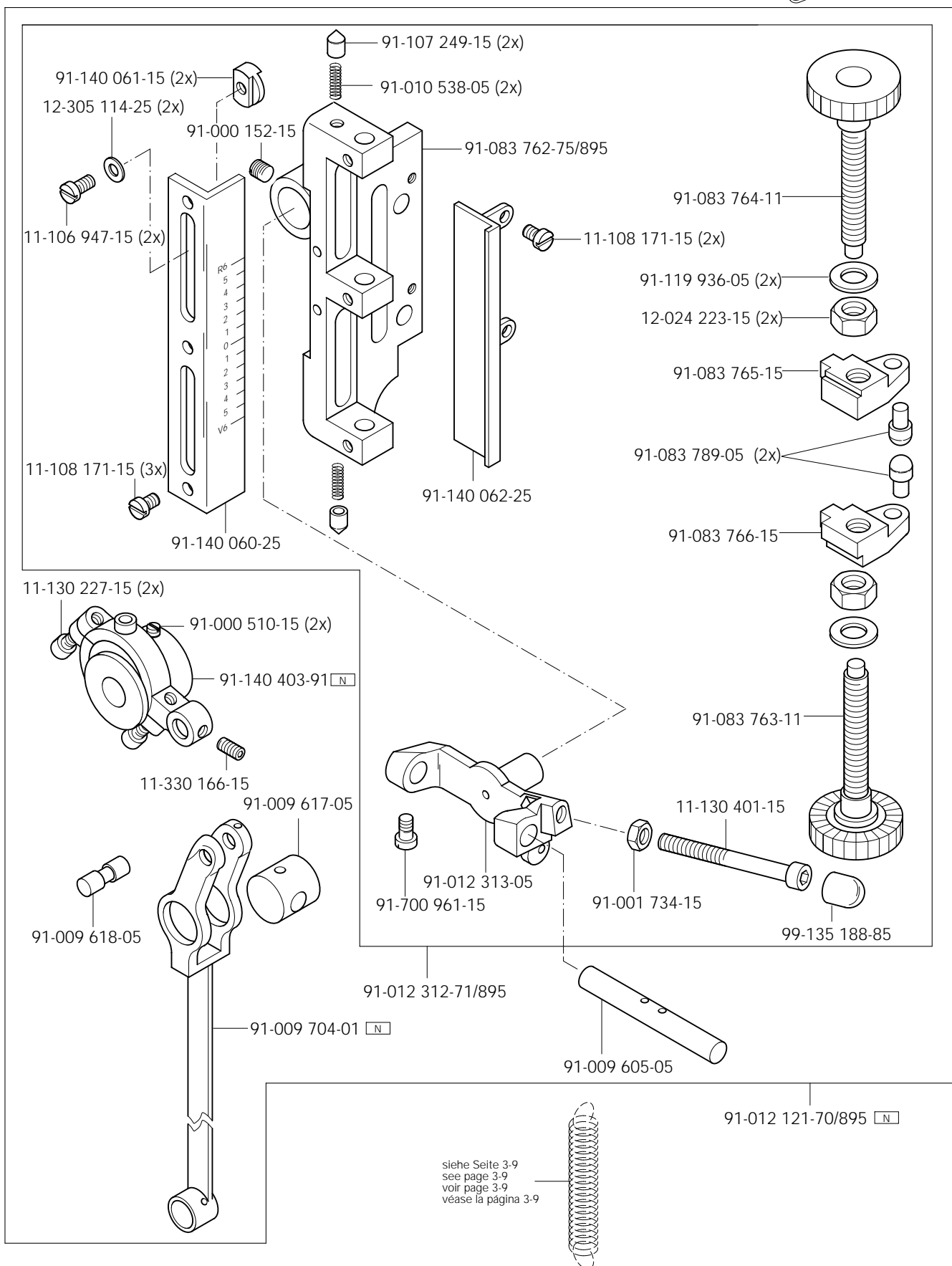

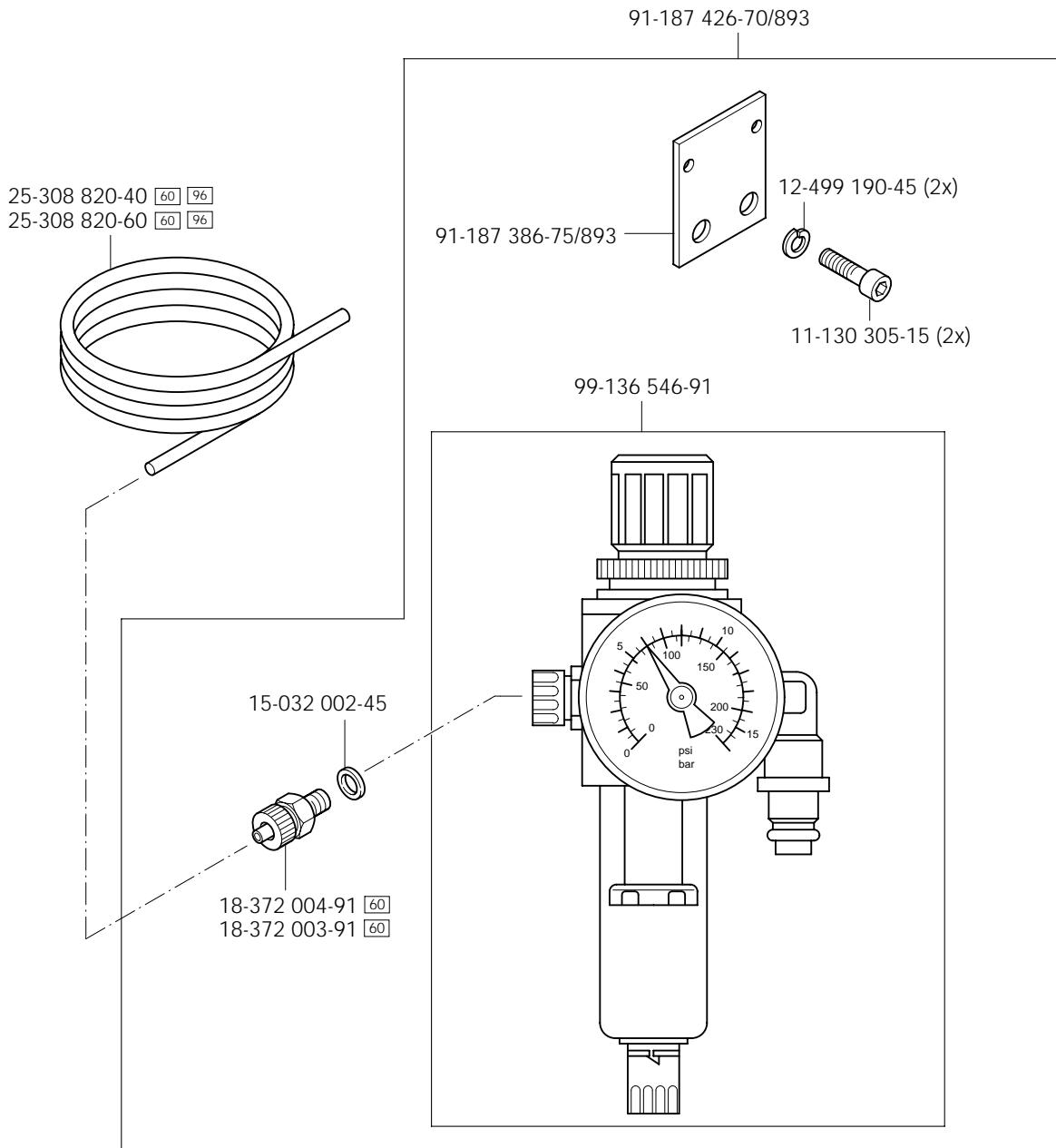

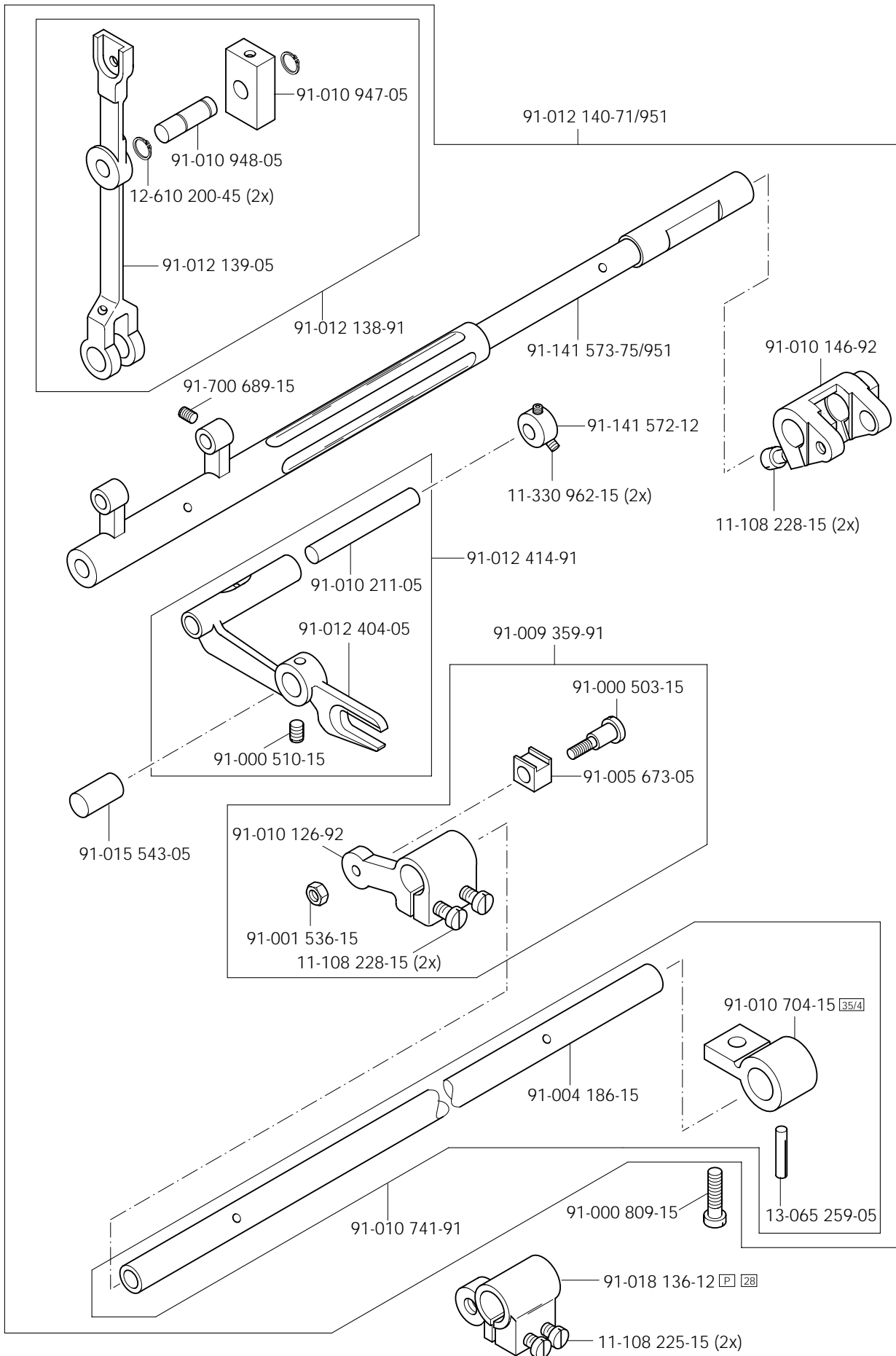

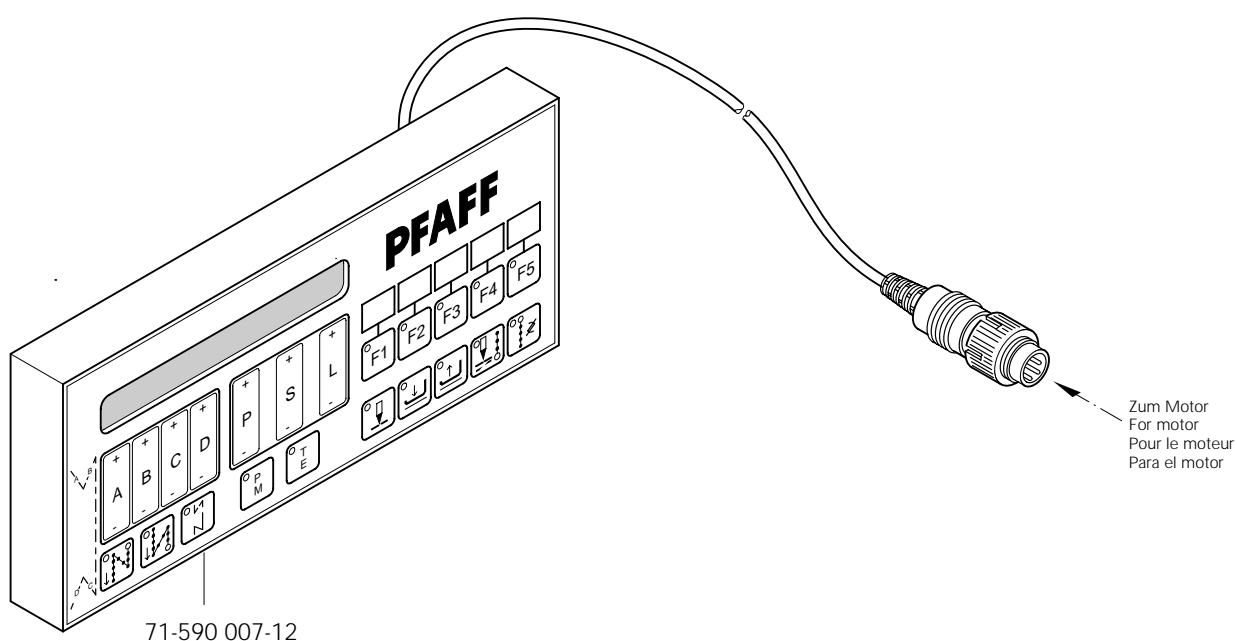

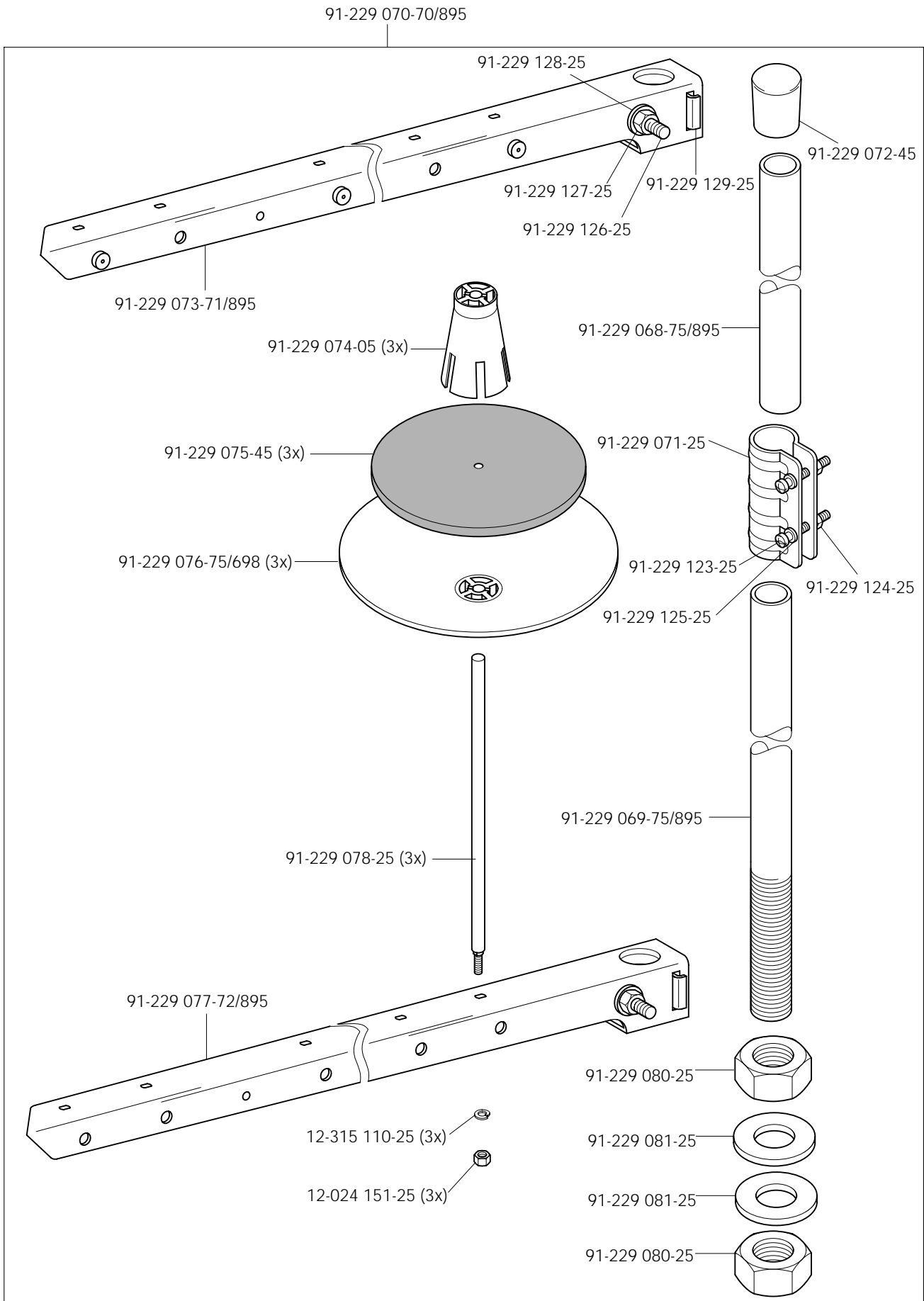

Einstellehren
 Adjustment gauges PFAFF 1295 CN
 Calibres PFAFF 1296 BN; CN
 Calibres de ajuste PFAFF 3713-2/01 CN

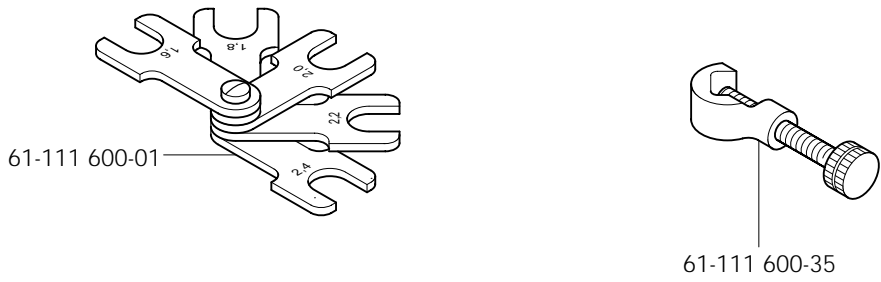

Teile zur Tischplatte
 Parts for table top PFAFF 1295 CN
 Pièces du plateau PFAFF 1296 BN; CN
 Piezas para el tablero PFAFF 3713-2/01 CN

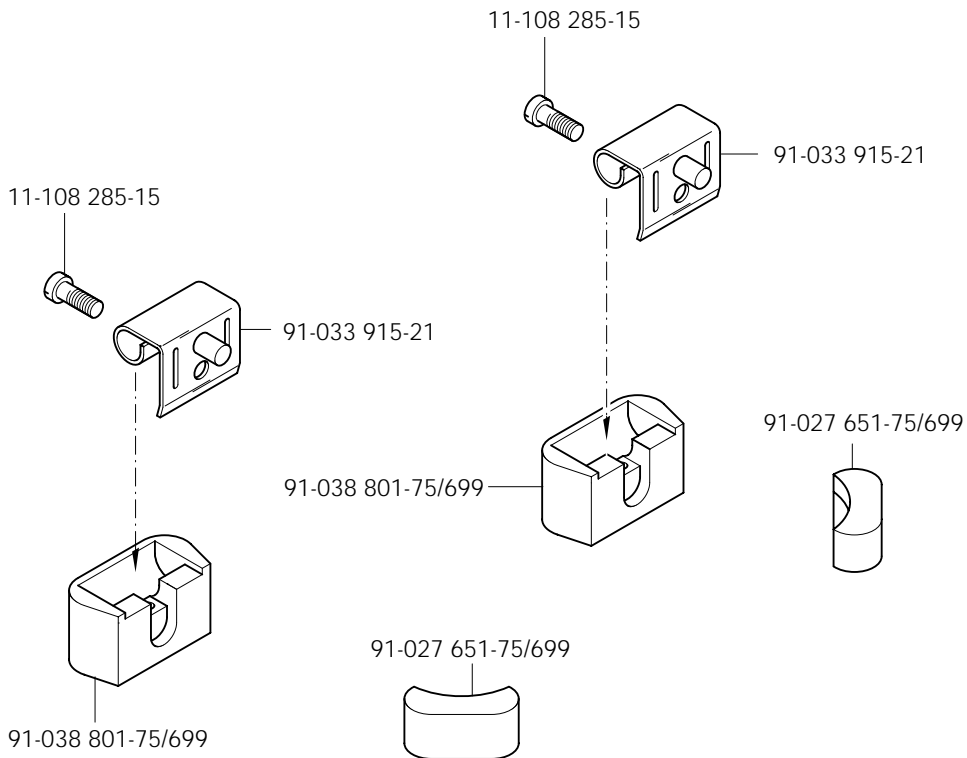

15

Fadenöler
Thread lubricator
Graisseur de fil
Lubricador del hilo

PFAFF 1295 CN
PFAFF 1296 BN; CN

28

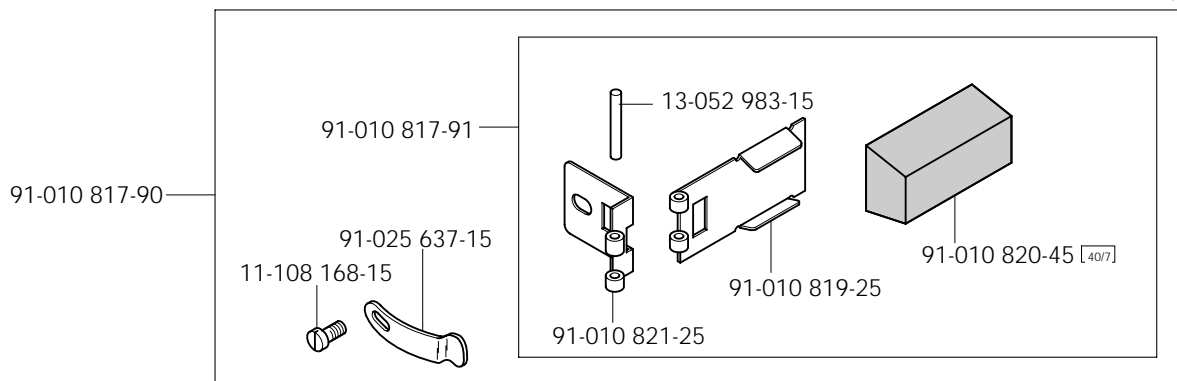
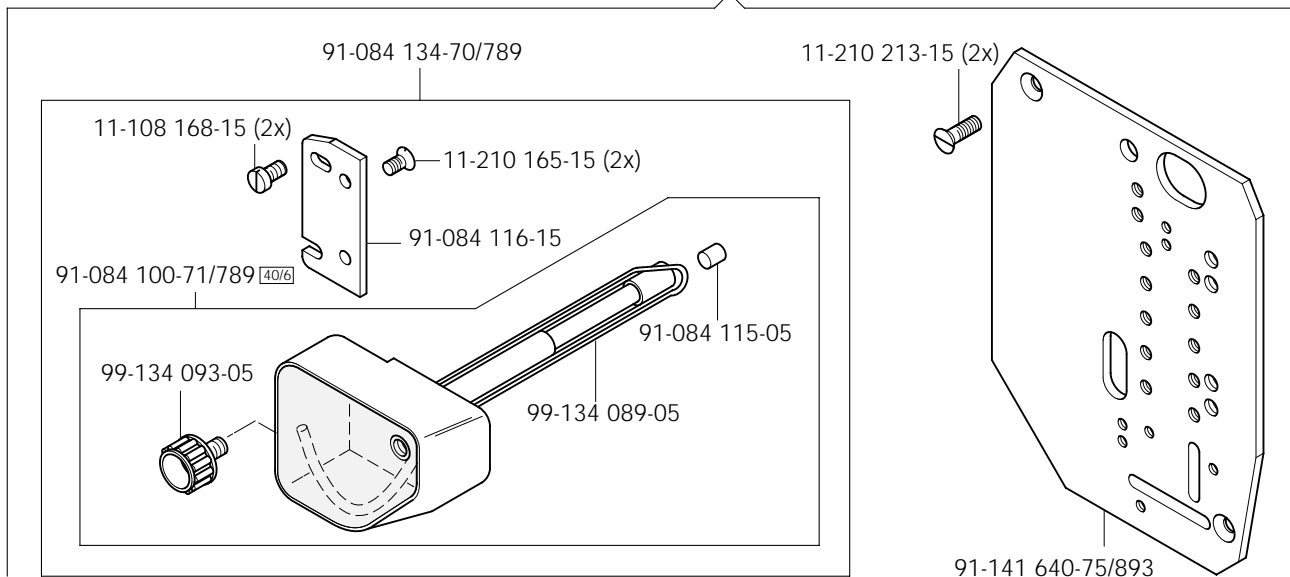

16

Keilriemen
V-belt
Courroie trapézoïdale
Correa trapezoidal

PFAFF 1295 CN
PFAFF 1296 BN; CN

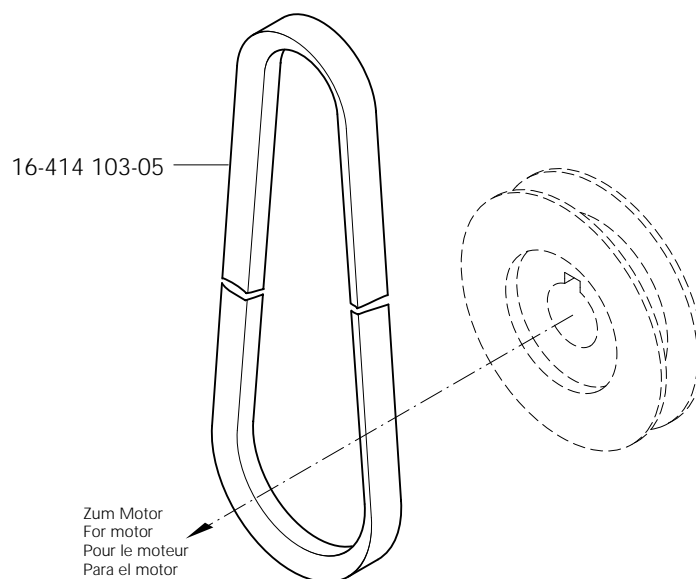

Keilriemenschutz (unter der Tischplatte)
 Belt guard (under table top)
 Garde-courroie (sous le plateau de table)
 Guardacorreas (parte inferior)

PFAFF 1295 CN
 PFAFF 1296 BN; CN

17

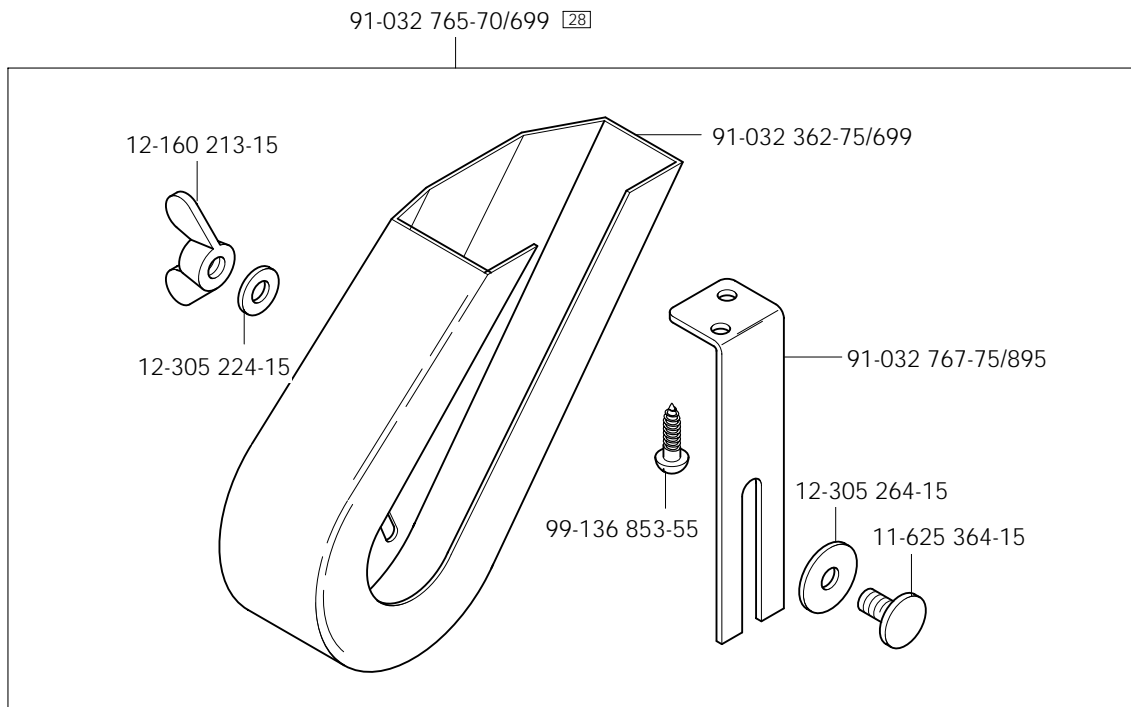

Knielüfterteile
 Knee lifter parts
 Pièces du releveur de genouillère
 Piezas del alzaprensateles por rodillera

PFAFF 1295 CN
 PFAFF 1296 BN; CN

18

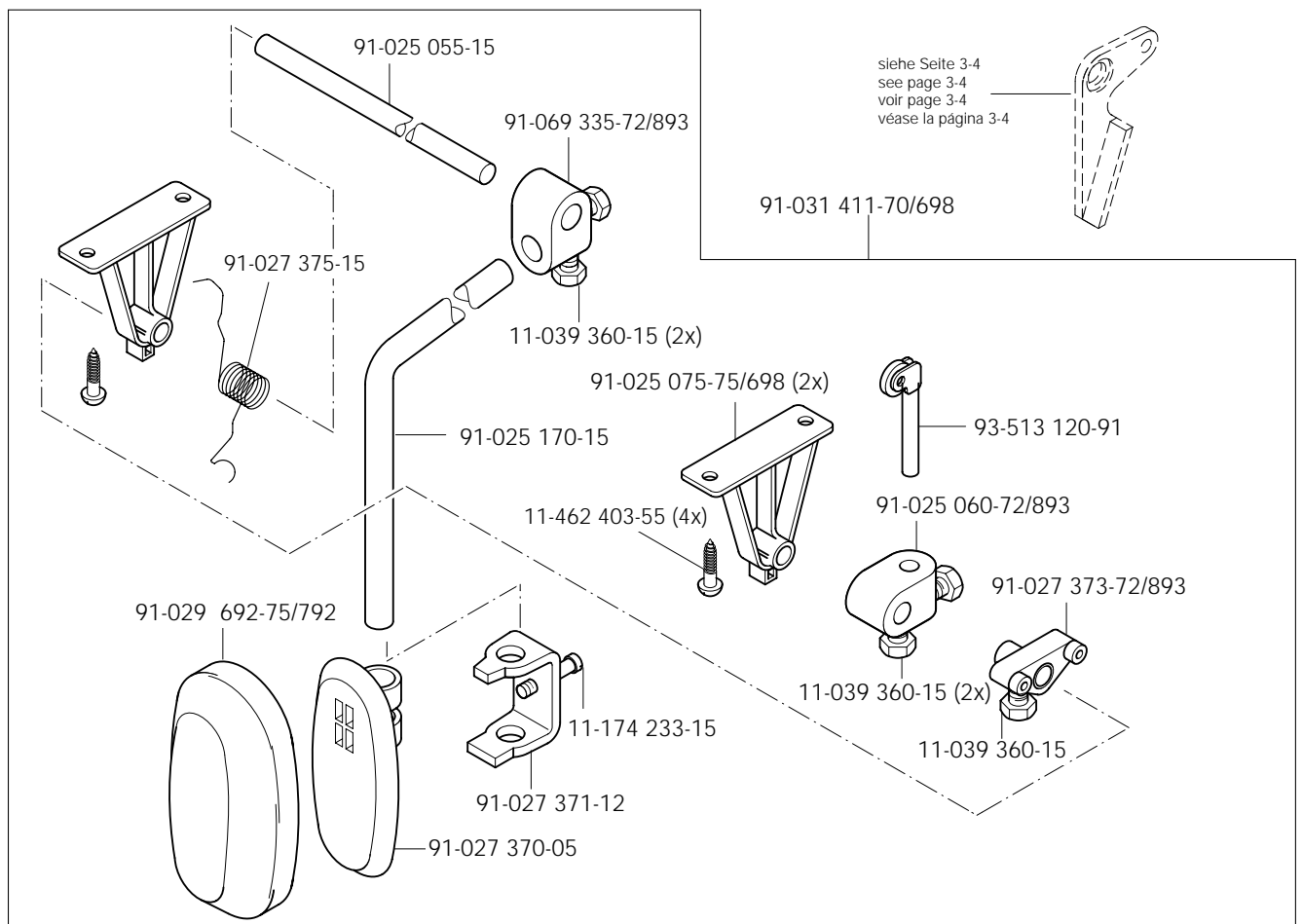

Öl Oil Huile Aceite	Mittelpunkts-Viskosität bei: Mean viscosity at: Viscosité moyenne à: Viscosidad media a:		Dichte bei: Density of: Densité à: Densidad a:		Bestellnummer für Behälter mit: Part number for can with: Numéro de commande pour récipients avec: Número de pedido para recipientes con:		
	°C	mm ² /s	°C	g/cm ³ (g/ml)	1 Liter 1 Litre 1 Litro	5 Liter 5 Litre 5 Litros	10 Liter 10 Litre 10 Litros
28-011 201-44	40	22,0	15	0,865	91-129 917-91	91-129 919-91	91-129 920-91
28-011 202-17 (Fadenschmiermittel) (Thread lubricant) (Agents de lubrication de fil) (Lubricantes del hilo)			21	0,810	91-129 941-91		

Fett Grease Graisse Grasa	Penetration Penetration Pénétration Penetración	Tropfpunkt Drip-point Point de suintement Punto de goteo	Bestellnummer für Behälter mit: Part number for can with: Numéro de commande pour récipients avec: Número de pedido para recipientes con:				
			mm/10	°C	0,25kg	0,5kg	1 kg
28-011 202-05							28-011 202-05
28-011 202-43	375 - 405	150				28-011 202-43	
28-011 202-47	220 - 250	185					28-011 202-47

Reinigungsmittel Cleansing agent Agents de nettoyage Limpiadores	Bestellnummer für Behälter mit: Part number for can with: Numéro de commande pour récipients avec: Número de pedido para recipientes con:		
	240 ml		
Isopropyl-Alkohol	95-665 735-91		

No.	Seite Page Pages Página	No.	Seite Page Pages Página	No.	Seite Page Pages Página	No.	Seite Page Pages Página
11-039 171-15	4 - 3, 4 - 4, 4 - 5	11-130 401-15	8 - 2	11-341 901-15	3 - 8, 3 - 12	12-499 190-45	9 - 1
11-039 174-15	5 - 3	11-130 955-15	3 - 9	11-341 902-15	3 - 8, 3 - 12, 5 - 3	12-610 170-45	3 - 2
11-039 222-15	3 - 3	11-173 090-15	5 - 1	11-462 118-55	3 - 1	12-610 190-45	3 - 2
11-039 225-15	3 - 3, 8 - 1	11-173 171-25	3 - 1	11-462 247-15	3 - 1	12-610 200-45	3 - 2, 3 - 10, 10 - 1
11-039 291-15	8 - 1	11-173 177-25	3 - 6	11-462 403-55	17 - 1	12-610 210-45	3 - 5
11-039 360-15	17 - 1	11-173 222-25	3 - 1	11-625 364-15	17 - 1	12-618 190-45	5 - 3
11-106 947-15	8 - 2	11-174 173-15	3 - 2	11-714 060-91	5 - 3	12-640 090-55	5 - 1
11-108 087-15	4 - 2, 4 - 4, 4 - 5	11-174 176-15	3 - 5	11-721 482-15	3 - 11	12-640 130-55	3 - 7, 3 - 12, 5 - 3
11-108 168-15	3 - 1, 5 - 3, 15 - 1	11-174 233-15	3 - 6, 17 - 1	11-721 522-15	3 - 11	12-640 150-55	3 - 12, 5 - 2, 5 - 3, 8 - 1
11-108 171-15	3 - 2, 5 - 3, 8 - 2	11-186 277-15	7 - 1, 8 - 1	12-005 154-25	3 - 1	12-640 170-55	3 - 6, 5 - 1, 5 - 3
11-108 174-15	3 - 1, 3 - 3, 4 - 3, 4 - 4, 4 - 5, 5 - 1, 5 - 3	11-186 962-15	3 - 9	12-005 175-15	8 - 1	12-640 190-55	5 - 3
11-108 177-15	3 - 2	11-187 017-15	3 - 4	12-005 195-15	3 - 9, 5 - 2	12-640 230-55	6 - 1
11-108 219-15	5 - 3	11-210 165-15	15 - 1	12-005 198-15	5 - 2	12-651 006-51	5 - 3
11-108 222-15	3 - 2, 5 - 3	11-210 168-25	3 - 6, 3 - 7	12-005 215-15	7 - 1, 8 - 1	13-052 187-15	5 - 3
11-108 225-15	3 - 10, 10 - 1	11-210 213-15	15 - 1	12-010 251-15	5 - 3	13-052 983-15	15 - 1
11-108 228-15	3 - 2, 3 - 3, 3 - 10, 10 - 1	11-210 273-15	3 - 8	12-024 151-25	3 - 1, 5 - 3, 12 - 1	13-064 383-05	3 - 6, 3 - 9
11-108 234-15	3 - 1	11-250 076-25	3 - 9	12-024 171-25	3 - 4	13-065 259-05	3 - 10, 10 - 1
11-108 285-15	3 - 1, 13 - 1	11-250 084-25	3 - 7	12-024 191-15	5 - 3	14-602 901-01	3 - 7
11-108 861-25	5 - 3	11-314 946-15	5 - 1	12-024 191-25	3 - 8	15-032 002-45	9 - 1
11-130 173-15	3 - 3	11-315 917-05	3 - 7	12-024 192-15	5 - 3	15-032 006-45	7 - 1, 8 - 1
11-130 179-15	5 - 2	11-317 971-15	4 - 3, 4 - 4, 4 - 5	12-024 223-15	8 - 2	15-711 050-51	3 - 3
11-130 185-15	3 - 3, 5 - 3	11-330 166-15	3 - 6, 3 - 9, 8 - 2	12-160 213-15	17 - 1	16-414 103-05	15 - 1
11-130 224-15	3 - 2	11-330 217-15	3 - 12	12-305 114-15	3 - 2, 3 - 3	18-372 003-91	9 - 1
11-130 227-15	3 - 8, 3 - 9, 7 - 1, 8 - 1, 8 - 2	11-330 220-15	3 - 3, 3 - 6	12-305 114-25	8 - 2	18-372 004-91	9 - 1
11-130 254-15	3 - 1	11-330 277-15	5 - 1	12-305 144-15	3 - 2, 3 - 8	18-372 008-91	7 - 1, 8 - 1
11-130 284-15	5 - 2	11-330 280-15	3 - 2, 3 - 3, 3 - 5, 3 - 7, 3 - 10, 3 - 12	12-305 174-15	4 - 2, 4 - 4	18-378 009-91	7 - 1, 8 - 1
11-130 293-15	3 - 10, 4 - 2, 4 - 4, 5 - 3	11-330 952-15	3 - 4, 3 - 7, 4 - 3, 4 - 4, 4 - 5	12-305 224-15	17 - 1	25-308 820-40	7 - 1, 8 - 1, 9 - 1
11-130 293-25	3 - 9	11-330 962-15	3 - 10, 10 - 1	12-305 264-15	17 - 1	25-308 820-60	9 - 1
11-130 299-15	4 - 2, 4 - 3, 4 - 4, 4 - 5	11-330 964-15	3 - 11	12-315 110-15	4 - 3, 4 - 4, 4 - 5	26-534 300-50	3 - 5, 3 - 7, 3 - 9
11-130 305-15	9 - 1	11-330 968-15	3 - 2	12-315 110-25	12 - 1	26-535 001-00	3 - 5
11-130 341-15	6 - 1	11-335 902-15	3 - 8, 3 - 12	12-335 191-15	4 - 2, 4 - 3, 4 - 4, 4 - 5 8 - 1	28-011 201-44	19 - 1
11-130 359-15	3 - 8	11-341 082-15	3 - 3	12-341 090-15	5 - 1	28-011 202-05	19 - 1
						28-011 202-17	19 - 1

No.	Seite Page Pages Página	No.	Seite Page Pages Página	No.	Seite Page Pages Página	No.	Seite Page Pages Página
28-011 202-43	19 - 1	91-000 783-15	4 - 2	91-009 717-01	3 - 7	91-011 778-05	3 - 3
28-011 202-47	19 - 1	91-000 809-15	10 - 1	91-010 022-05	3 - 9	91-011 818-91	3 - 8
61-111 600-01	13 - 1	91-000 928-15	4 - 1	91-010 026-21	3 - 6	91-011 821-91	3 - 12
61-111 600-35	13 - 1	91-001 013-15	3 - 8	91-010 088-05	4 - 3, 4 - 4, 4 - 5	91-011 823-90	3 - 11
71-170 001-31	5 - 3	91-001 512-15	3 - 7, 3 - 9, 4 - 2	91-010 115-05	3 - 6	91-011 825-90	3 - 11
71-210 001-74	5 - 3	91-001 522-25	3 - 6	91-010 116-05	3 - 6	91-011 830-92	5 - 3
71-370 001-32	5 - 3	91-001 536-15	3 - 10, 10 - 1	91-010 126-92	3 - 10, 10 - 1	91-011 832-75/893	3 - 1
71-590 007-12	11 - 1	91-001 734-15	8 - 2	91-010 146-92	3 - 10, 10 - 1	91-011 833-12	5 - 2
91-000 011-15	3 - 7	91-003 113-05	3 - 1	91-010 179-05	3 - 6	91-011 848-91	3 - 5
91-000 150-15	4 - 3, 4 - 4, 4 - 5	91-004 005-05	3 - 6	91-010 180-05	3 - 6	91-011 944-70/895	3 - 9
91-000 152-15	8 - 2	91-004 006-05	3 - 6	91-010 181-25	3 - 6	91-011 945-71/895	3 - 9
91-000 172-15	4 - 2, 4 - 4	91-004 186-15	3 - 10, 10 - 1	91-010 183-05	3 - 6	91-011 954-05	4 - 3, 4 - 4, 4 - 5
91-000 172-25	4 - 3, 4 - 5	91-004 309-05	3 - 2	91-010 184-05	3 - 6	91-011 957-15	4 - 2, 4 - 4, 4 - 5
91-000 226-15	4 - 2	91-005 673-05	3 - 10, 10 - 1	91-010 185-05	3 - 6	91-011 958-91	4 - 2, 4 - 4, 4 - 5
91-000 277-25	4 - 2, 4 - 4	91-006 505-05	3 - 6	91-010 186-15	3 - 6	91-011 963-05	4 - 3, 4 - 4, 4 - 5
91-000 335-15	4 - 2	91-006 616-05	3 - 7, 3 - 9	91-010 196-05	3 - 7	91-011 964-25	4 - 3, 4 - 4, 4 - 5
91-000 366-15	3 - 6	91-007 116-05	3 - 2	91-010 211-05	3 - 10, 10 - 1	91-011 966-15	5 - 3
91-000 390-05	4 - 1	91-008 204-05	3 - 9	91-010 221-05	3 - 10	91-011 967-15	5 - 3
91-000 405-15	3 - 7, 4 - 2	91-008 618-05	3 - 7, 3 - 9	91-010 538-05	8 - 2	91-011 968-15	5 - 3
91-000 412-15	4 - 2, 4 - 4, 4 - 5	91-009 148-05	3 - 5	91-010 596-05	3 - 7, 3 - 9	91-011 969-05	5 - 3
91-000 412-25	4 - 5	91-009 149-05	3 - 10	91-010 704-15	3 - 10, 10 - 1	91-011 970-01	5 - 3
91-000 456-15	3 - 7	91-009 343-05	3 - 12	91-010 741-91	10 - 1	91-011 974-15	5 - 3
91-000 486-15	4 - 4	91-009 359-91	3 - 10, 10 - 1	91-010 817-90	15 - 1	91-011 975-15	5 - 3
91-000 503-15	3 - 10, 10 - 1	91-009 408-05	3 - 12	91-010 817-91	15 - 1	91-011 976-15	5 - 3
91-000 510-15	3 - 7, 3 - 9, 3 - 10, 8 - 2, 10 - 1	91-009 603-75/895	3 - 9	91-010 819-25	15 - 1	91-011 977-11	5 - 3
91-000 511-15	3 - 7	91-009 605-05	3 - 9, 8 - 2	91-010 820-45	15 - 1	91-011 979-15	5 - 3
91-000 522-15	3 - 9	91-009 609-05	3 - 9	91-010 821-25	15 - 1	91-011 980-05	5 - 3
91-000 524-05	3 - 6	91-009 617-05	3 - 9, 8 - 2	91-010 825-05	3 - 2	91-011 981-05	5 - 3
91-000 525-15	4 - 1	91-009 618-05	3 - 9, 8 - 2	91-010 937-05	3 - 6	91-011 982-11	5 - 3
91-000 529-15	4 - 1	91-009 652-91	3 - 6	91-010 947-05	3 - 10, 10 - 1	91-011 985-15	5 - 3
91-000 604-15	4 - 2, 4 - 4, 4 - 5	91-009 702-02	3 - 9	91-010 948-05	3 - 10, 10 - 1	91-011 991-91	5 - 3
91-000 762-15	4 - 2, 4 - 5	91-009 704-01	3 - 9, 8 - 2	91-010 950-91	3 - 10	91-011 992-15	5 - 3
91-000 781-15	4 - 2, 4 - 4	91-009 709-05	3 - 9	91-011 112-05	4 - 3, 4 - 4, 4 - 5	91-011 993-15	5 - 3

No.	Seite Page Pages Página	No.	Seite Page Pages Página	No.	Seite Page Pages Página	No.	Seite Page Pages Página
91-011 995-91	5 - 2	91-012 644-05	4 - 2, 4 - 5	91-018 268-73/001	4 - 4	91-018 994-74/002	4 - 2
91-011 996-12	5 - 2	91-012 652-73/002	4 - 2	91-018 268-73/002	4 - 4	91-018 997-21	4 - 3, 4 - 4, 4 - 5
91-012 096-15	4 - 2, 4 - 4, 4 - 5	91-012 653-73/001	4 - 4	91-018 268-73/003	4 - 4	91-018 999-05	4 - 3, 4 - 4, 4 - 5
91-012 097-91	5 - 3	91-012 653-73/002	4 - 4	91-018 269-73/002	4 - 2	91-019 676-05	3 - 5, 3 - 7, 3 - 9
91-012 108-91	5 - 3	91-012 653-73/003	4 - 4	91-018 284-91	4 - 1	91-019 891-05	4 - 1
91-012 112-15	5 - 3	91-012 653-73/004	4 - 4	91-018 285-91	4 - 1	91-021 202-05	4 - 3, 4 - 4, 4 - 5
91-012 113-05	5 - 2	91-012 653-73/005	4 - 4	91-018 293-05	4 - 1	91-021 283-05	5 - 3
91-012 115-25	4 - 2, 4 - 4, 4 - 5	91-012 653-73/006	4 - 4	91-018 339-05	4 - 1	91-021 486-41	6 - 1
91-012 121-70/895	8 - 2	91-012 696-75/895	4 - 4, 4 - 5	91-018 340-91	4 - 1	91-025 055-15	17 - 1
91-012 138-91	10 - 1	91-012 697-74/001	4 - 4, 4 - 5	91-018 341-91	4 - 1	91-025 060-72/893	17 - 1
91-012 139-05	10 - 1	91-012 697-74/002	4 - 4, 4 - 5	91-018 344-05	4 - 1	91-025 075-75/698	17 - 1
91-012 140-71/951	10 - 1	91-012 697-74/003	4 - 4, 4 - 5	91-018 346-01	4 - 1	91-025 170-15	17 - 1
91-012 272-11	5 - 3	91-012 697-74/004	4 - 4, 4 - 5	91-018 348-91	4 - 1	91-025 637-15	15 - 1
91-012 312-71/895	8 - 2	91-012 697-74/005	4 - 4, 4 - 5	91-018 349-05	4 - 1	91-027 370-05	17 - 1
91-012 313-05	8 - 2	91-012 697-74/006	4 - 4, 4 - 5	91-018 350-05	4 - 1	91-027 371-12	17 - 1
91-012 404-05	3 - 10, 10 - 1	91-012 698-73/002	4 - 2	91-018 358-75/770	3 - 7	91-027 373-72/893	17 - 1
91-012 414-91	3 - 10, 10 - 1	91-013 040-92	3 - 7	91-018 415-92	3 - 7	91-027 375-15	17 - 1
91-012 492-25	3 - 9	91-013 091-05	3 - 6	91-018 439-05	4 - 1	91-027 651-75/699	13 - 1
91-012 605-74/002	4 - 2	91-013 153-05	3 - 12	91-018 480-05	4 - 1	91-029 692-75/792	17 - 1
91-012 606-74/012	4 - 2	91-013 188-05	3 - 12	91-018 481-05	4 - 1	91-031 411-70/698	17 - 1
91-012 607-75/895	4 - 3	91-013 191-05	3 - 6	91-018 482-91	4 - 1	91-032 087-45	3 - 1
91-012 608-75/895	4 - 2	91-013 193-91	3 - 6	91-018 483-91	4 - 1	91-032 362-75/699	17 - 1
91-012 609-25	4 - 3, 4 - 4, 4 - 5	91-015 514-92	4 - 3, 4 - 4, 4 - 5	91-018 484-05	4 - 1	91-032 765-70/699	17 - 1
91-012 612-05	4 - 3, 4 - 4, 4 - 5	91-015 519-05	3 - 6	91-018 487-05	3 - 8	91-032 767-75/895	17 - 1
91-012 625-75/895	4 - 2	91-015 533-05	4 - 4	91-018 515-01	3 - 7, 3 - 9	91-033 915-21	13 - 1
91-012 626-25	4 - 2	91-015 542-05	3 - 10	91-018 649-01	4 - 1	91-038 801-75/699	13 - 1
91-012 628-74/002	4 - 2	91-015 543-05	3 - 10, 10 - 1	91-018 676-91	4 - 1	91-056 192-25	3 - 8
91-012 630-05	4 - 3	91-015 657-01	3 - 8	91-018 682-05	4 - 1	91-056 193-25	3 - 8
91-012 631-75/895	4 - 2	91-015 664-05	3 - 10	91-018 799-91	3 - 6	91-056 578-91	3 - 8
91-012 632-75/895	4 - 2	91-017 378-15	5 - 1	91-018 992-74/001	4 - 4, 4 - 5	91-057 720-15	3 - 2
91-012 637-21	4 - 3	91-018 136-12	3 - 10, 10 - 1	91-018 992-74/002	4 - 4, 4 - 5	91-063 048-05	3 - 5
91-012 638-01	4 - 3, 4 - 4, 4 - 5	91-018 257-05	4 - 3, 4 - 4, 4 - 5	91-018 992-74/003	4 - 4, 4 - 5	91-063 051-01	3 - 5
				91-018 993-74/002	4 - 2	91-069 037-15	3 - 12

No.	Seite Page Pages Página	No.	Seite Page Pages Página	No.	Seite Page Pages Página	No.	Seite Page Pages Página
91-069 043-15	3 - 5	91-118 430-25	3 - 6	91-140 342-01	3 - 3	91-141 312-71/951	3 - 3
91-069 335-72/893	17 - 1	91-118 681-05	3 - 7	91-140 347-01	3 - 2	91-141 313-75/951	3 - 3
91-069 709-12	4 - 3, 4 - 4, 4 - 5	91-118 683-05	3 - 7	91-140 349-05	3 - 2, 3 - 3	91-141 314-71/951	3 - 3
91-083 762-75/895	8 - 2	91-118 685-05	3 - 7	91-140 351-91	3 - 2	91-141 315-71/951	3 - 3
91-083 763-11	8 - 2	91-118 940-05	3 - 7	91-140 352-05	3 - 2	91-141 429-15	3 - 1
91-083 764-11	8 - 2	91-119 421-05	3 - 2	91-140 353-05	3 - 2	91-141 430-15	3 - 1
91-083 765-15	8 - 2	91-119 590-05	3 - 9	91-140 358-05	3 - 2	91-141 442-15	3 - 6
91-083 766-15	8 - 2	91-119 936-05	8 - 2	91-140 359-05	3 - 2	91-141 443-15	3 - 6
91-083 789-05	8 - 2	91-120 735-92	3 - 12	91-140 360-05	3 - 2	91-141 452-12	3 - 8
91-084 100-71/789	15 - 1	91-129 805-90	3 - 1	91-140 363-12	3 - 2	91-141 455-91	3 - 8
91-084 115-05	15 - 1	91-129 917-91	19 - 1	91-140 366-05	3 - 2	91-141 502-15	3 - 2
91-084 116-15	15 - 1	91-129 919-91	19 - 1	91-140 367-05	3 - 2	91-141 558-05	4 - 3, 4 - 4, 4 - 5
91-084 134-70/789	15 - 1	91-129 920-91	19 - 1	91-140 368-05	3 - 2	91-141 572-12	3 - 10, 10 - 1
91-095 850-91	5 - 3	91-129 941-91	19 - 1	91-140 372-05	3 - 2	91-141 573-75/951	3 - 10, 10 - 1
91-099 904-45	5 - 3	91-140 060-25	8 - 2	91-140 378-05	3 - 3	91-141 612-91	3 - 8
91-100 281-25	3 - 7	91-140 061-15	8 - 2	91-140 379-92	3 - 3	91-141 617-75/698	3 - 1
91-100 351-25	4 - 3, 4 - 4, 4 - 5	91-140 062-25	8 - 2	91-140 394-05	3 - 2	91-141 618-75/895	3 - 1
91-100 366-15	3 - 2	91-140 068-75/951	3 - 4	91-140 403-91	3 - 9, 8 - 2	91-141 619-05	3 - 7
91-105 005-15	3 - 3	91-140 085-05	3 - 3	91-140 450-25	3 - 2	91-141 620-72/893	3 - 8
91-105 447-25	3 - 6	91-140 086-12	3 - 3	91-140 481-01	3 - 8	91-141 621-75/895	3 - 1
91-107 162-15	5 - 1	91-140 101-05	3 - 7	91-140 516-75/770	3 - 7, 3 - 11	91-141 622-75/698	3 - 1
91-107 249-15	8 - 2	91-140 102-05	3 - 7	91-140 560-90	3 - 12	91-141 623-75/698	3 - 1
91-107 933-15	5 - 2	91-140 120-05	3 - 8	91-140 561-91	3 - 12	91-141 624-75/895	3 - 1
91-107 935-11	5 - 2	91-140 123-91	3 - 8	91-140 562-05	3 - 12	91-141 625-75/895	6 - 1
91-107 939-15	5 - 2	91-140 149-15	3 - 1	91-140 563-05	3 - 12	91-141 626-05	3 - 4
91-108 015-02	3 - 7	91-140 201-05	3 - 11	91-140 564-92	3 - 12	91-141 628-75/895	3 - 1
91-113 017-91	3 - 6	91-140 202-05	3 - 11	91-140 582-15	6 - 1	91-141 633-15	5 - 1
91-113 019-15	5 - 1	91-140 273-05	3 - 3, 3 - 5	91-141 087-05	3 - 12	91-141 640-75/893	15 - 1
91-113 020-25	5 - 1	91-140 292-91	3 - 3	91-141 099-05	3 - 3	91-141 663-15	3 - 4
91-113 023-92	5 - 1	91-140 325-91	3 - 5	91-141 100-91	3 - 2	91-141 664-75/895	3 - 1
91-113 027-15	5 - 1	91-140 327-91	3 - 5	91-141 101-15	3 - 2	91-141 665-91	3 - 3
91-118 099-91	3 - 7	91-140 328-91	3 - 5	91-141 102-05	3 - 2	91-141 666-05	3 - 3
91-118 196-12	3 - 2	91-140 336-15	3 - 4	91-141 307-05	3 - 3	91-141 667-05	3 - 3

No.	Seite Page Pages Página	No.	Seite Page Pages Página	No.	Seite Page Pages Página	No.	Seite Page Pages Página
91-141 668-15	3 - 2	91-173 664-15	3 - 3	91-229 143-70/895	3 - 1	99-135 585-05	3 - 8
91-141 674-05	3 - 9	91-174 783-05	3 - 7	91-229 144-75/895	3 - 1	99-136 072-95	8 - 1
91-141 679-71/698	3 - 9	91-174 879-05	3 - 8	91-229 145-75/895	3 - 1	99-136 546-91	9 - 1
91-141 688-90	3 - 1	91-175 023-05	3 - 12	91-229 146-75/895	3 - 1	99-136 853-55	17 - 1
91-141 694-05	3 - 3	91-175 126-05	3 - 12	91-266 397-01	3 - 7	99-137 001-05	3 - 1
91-141 710-72/893	3 - 8	91-175 171-05	5 - 1	91-700 029-15	3 - 4	99-137 151-45	3 - 7
91-141 760-15	5 - 1	91-176 267-05	3 - 2	91-700 082-15	3 - 6	99-137 227-91	7 - 1
91-141 818-15	3 - 4	91-176 327-25	5 - 1	91-700 364-25	3 - 1	99-137 228-91	8 - 1
91-141 829-92	3 - 4	91-176 328-05	5 - 1	91-700 412-25	3 - 6		
91-141 831-15	3 - 4	91-176 329-05	5 - 1	91-700 510-15	3 - 3		
91-141 848-91	3 - 2	91-176 332-25	3 - 6	91-700 592-15	3 - 4		
91-141 850-91	3 - 2	91-187 386-75/893	9 - 1	91-700 689-15	3 - 7, 3 - 10, 3 - 12, 10 - 1		
91-141 851-91	3 - 2	91-187 426-70/893	9 - 1	91-700 785-15	3 - 11, 5 - 3		
91-141 852-91	3 - 2	91-229 068-75/895	12 - 1	91-700 961-15	3 - 9, 8 - 2		
91-141 853-91	3 - 3	91-229 069-75/895	12 - 1	91-701 344-15	4 - 2, 4 - 4, 4 - 5		
91-141 859-75/895	4 - 3, 4 - 4, 4 - 5	91-229 070-70/895	12 - 1	91-709 610-71/698	3 - 9		
91-141 861-77/895	4 - 3, 4 - 4, 4 - 5	91-229 071-25	12 - 1	93-513 120-91	17 - 1		
91-141 863-75/895	4 - 2	91-229 072-45	12 - 1	95-215 000-04/261	7 - 1, 8 - 1		
91-141 864-75/895	4 - 4	91-229 073-71/895	12 - 1	95-215 000-04/288	8 - 1		
91-141 866-75/895	4 - 2	91-229 074-05	12 - 1	95-215 040-08/772	8 - 1		
91-141 871-77/895	4 - 3	91-229 075-45	12 - 1	95-215 040-15/927	8 - 1		
91-141 872-75/895	4 - 2	91-229 076-75/698	12 - 1	95-215 040-15/928	8 - 1		
91-166 452-21	3 - 8	91-229 077-72/895	12 - 1	95-215 040-15/930	7 - 1		
91-166 559-25	3 - 6	91-229 078-25	12 - 1	95-215 040-16/155	8 - 1		
91-166 670-15	3 - 1	91-229 080-25	12 - 1	95-215 040-16/156	7 - 1, 8 - 1		
91-168 154-05	5 - 3	91-229 081-25	12 - 1	95-215 040-16/160	8 - 1		
91-168 319-12	3 - 11, 5 - 3	91-229 123-25	12 - 1	95-215 040-16/183	7 - 1		
91-168 480-15	3 - 8	91-229 124-25	12 - 1	95-665 735-91	19 - 1		
91-169 523-05	3 - 3	91-229 125-25	12 - 1	96-711 962-05	3 - 2		
91-171 042-05	3 - 7	91-229 126-25	12 - 1	99-134 089-05	15 - 1		
91-171 049-05	3 - 7	91-229 127-25	12 - 1	99-134 093-05	15 - 1		
91-171 653-05	5 - 3	91-229 128-25	12 - 1	99-135 188-85	8 - 2		
91-171 808-05	3 - 2	91-229 129-25	12 - 1	99-135 496-95	8 - 1		

PFAFF

1295

1296

Unterklassen-Ausstattung

Subclass parts

Composition des sous-classes

Composición de las subclases

3713-2/01

-6/01 AN[◆]

Für allgemeine Näharbeiten.
Standardform des Teilesatzes.

For plain seaming operations.
Standard part set.

Travaux d'utilité courante.
Jeu de pièces standard.

Para trabajos de costura en.
Juego de piezas estándar.

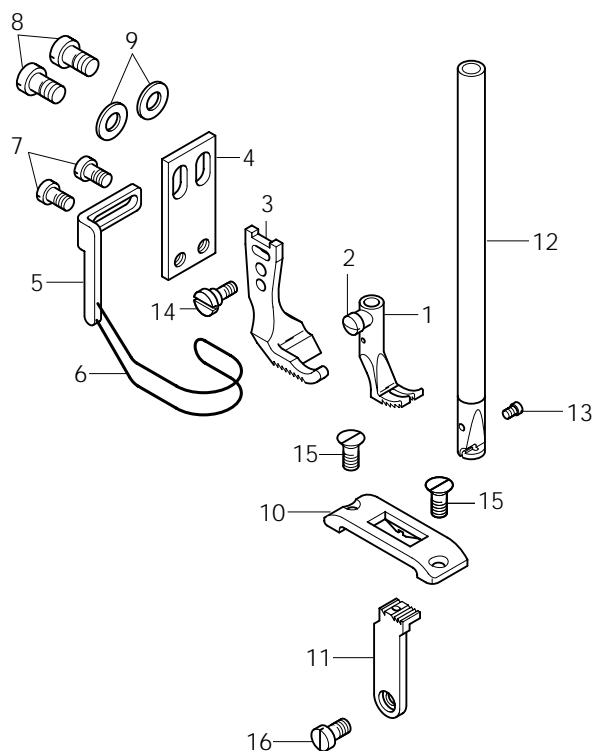

Pos.-Nr. Item No. N° pos. N° de pos.	Teile-Nr. Part No. N° de pièces N° de piezas
1 - 11	91-202 136-93/001
1 - 2	91-049 269-93/006
2	91-000 085-15
3	91-049 585-04/004
4 - 7	91-057 721-91
4	91-057 720-15
5 - 6	91-057 697-91
5	91-154 702-15
6	91-055 205-05 3
7	11-108 171-15

Pos.-Nr. Item No. N° pos. N° de pos.	Teile-Nr. Part No. N° de pièces N° de piezas
8	11-108 222-15
9	12-305 144-15
10	91-048 319-04/002
11	91-045 601-04/002
12 - 13	91-710 650-92
13	91-173 664-15
14	91-100 366-15
15	91-000 277-25
16	91-000 781-15

-6/01-900/56 CN[◆]

Für allgemeine Näharbeiten.
 Standardform des Teilesatzes.

For plain seaming operations.
 Standard part set.

Travaux d'utilité courante.
 Jeu de pièces standard.

Para trabajos de costura en.
 Juego de piezas estándar.

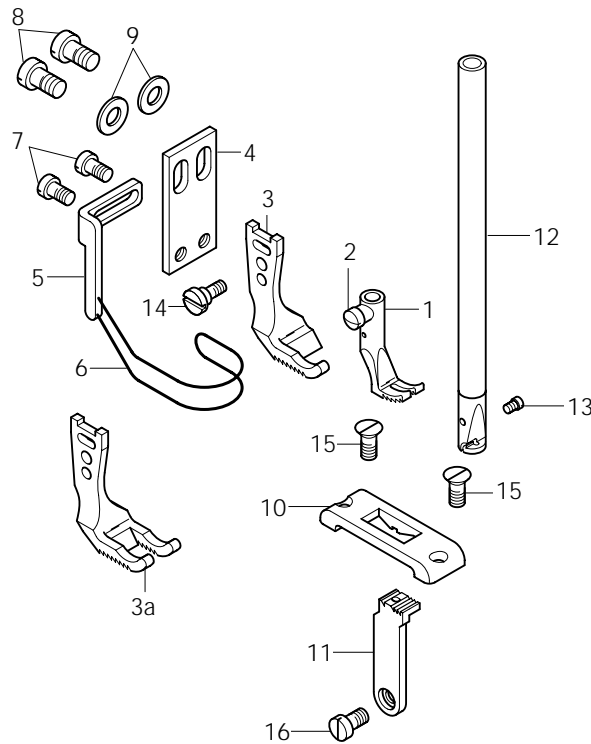

Pos.-Nr. Item No. N° pos. N° de pos.	Teile-Nr. Part No. N° de piezas N° de pieza
1 - 11	91-202 137-93/001 91-202 137-93/002 28
1 - 2	91-049 269-93/006
2	91-000 085-15
3 3a	91-049 585-04/004 91-046 970-05 28
4 - 7	91-057 721-91
4	91-057 720-15
5 - 6	91-057 697-91
5	91-154 702-15
6	91-055 205-05 3

Pos.-Nr. Item No. N° pos. N° de pos.	Teile-Nr. Part No. N° de piezas N° de pieza
7	11-108 171-15
8	11-108 222-15
9	12-305 144-15
10	91-158 292-05
11	91-059 254-04/001
12 - 13	91-710 650-92
13	91-173 664-15
14	91-100 366-15
15	91-000 277-25
16	91-000 781-15

-6/37-900/56 CN♦

Zum Übersteppen von Seitennähten im Hüftbogenbereich bei Jeans etc. Spezialteilesatz mit Anschlägen für rechte und linke Teile.

For top.stitching side seams in the hip curve on jeans, etc. Special part set with edge guides for right- and left parts.

Pour le surpiquage de coutures de côtés sur l'arrondi de la hanche pour les jeans, etc., jeu de pièces spécial avec butées pour pièces de droite et de gauche.

Para sobrepespuntar las costuras laterales en la zona de las caderas de vaqueros etc., juego de piezas especial con toques para oiezas izquierdas y derechas.

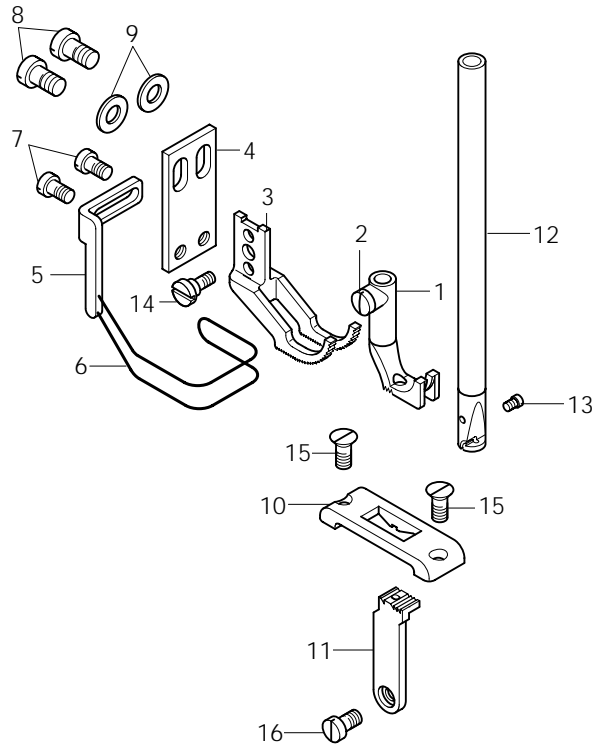

Pos.-Nr. Item No. N° pos. N° de pos.	Teile-Nr. Part No. N° de pieces N° de pieza
1 - 11	91-202 189-93/001
1 - 2	91-149 200-93/001
2	91-000 085-15
3	91-049 792-04/004
4 - 7	91-057 806-91
4	91-057 720-15
5 - 6	91-057 807-91
5	91-154 702-15
6	91-057 808-05 3
7	11-108 171-15

Pos.-Nr. Item No. N° pos. N° de pos.	Teile-Nr. Part No. N° de pieces N° de pieza
8	11-108 222-15
9	12-305 144-15
10	91-158 292-05
11	91-059 254-04/001
12 - 13	91-710 650-92
13	91-173 664-15
14	91-100 366-15
15	91-000 277-25
16	91-000 781-15

-17/01-940/01 CN♦

Arbeitsgang
Operation
Opération
Operación

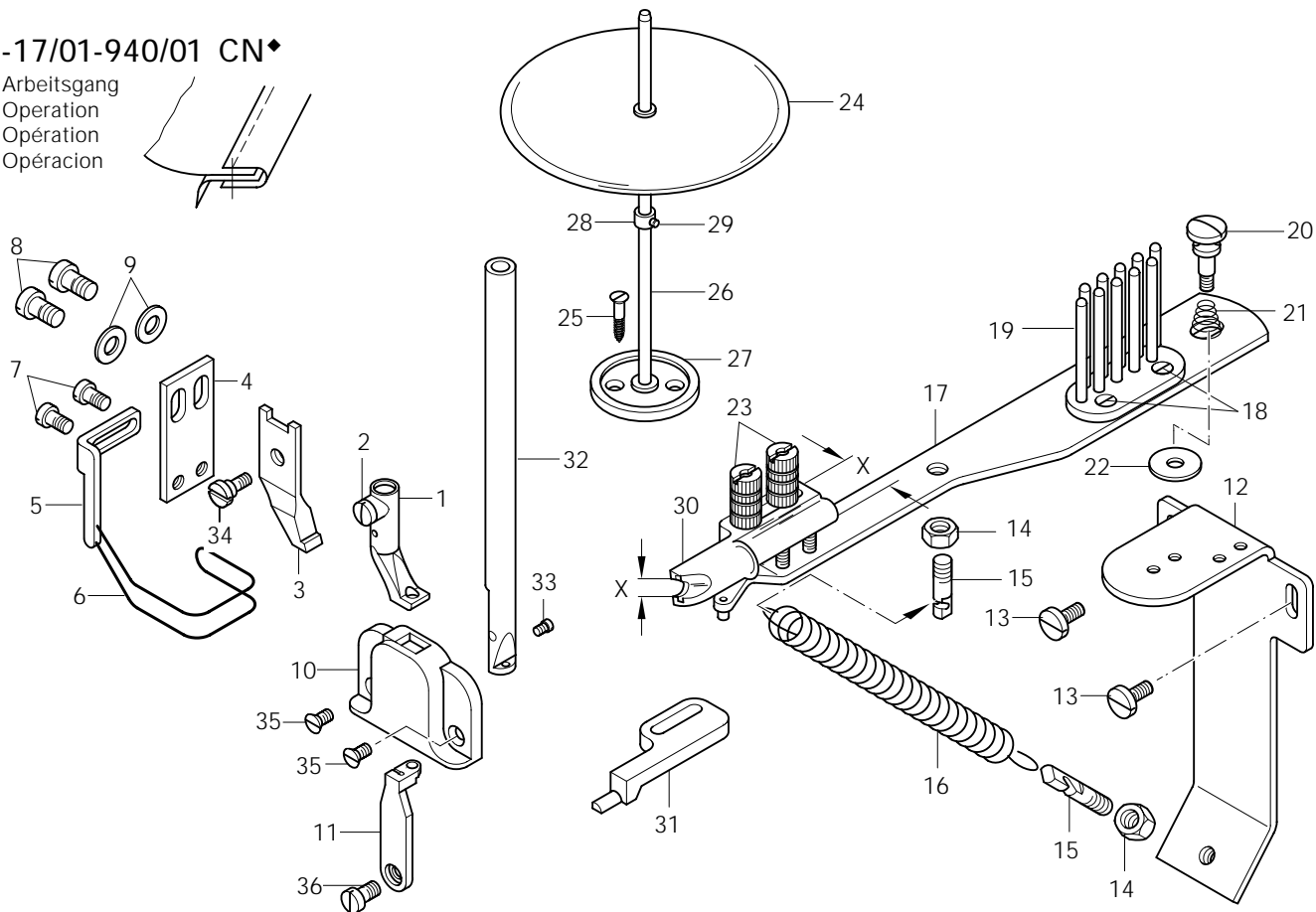

Pos.-Nr. Item No. N° pos. N° de pos.	Teile-Nr. Part No. N° de piezas N° de pieza
1 - 23	91-202 189-93/001
1 - 2	91-046 546-93/007
2	91-000 085-15
3	91-046 547-04/003
4 - 7	91-057 721-91
4	91-057 720-15
5 - 6	91-057 697-91
5	91-154 702-15
6	91-055 205-05 3
7	11-108 171-15
8	11-108 222-15
9	12-305 144-15
10	91-048 487-04/002
11	91-047 169-04/002
12 - 23	91-156 732-90/002
12	91-156 732-25
13	91-000 717-15
14	12-005 195-15
15	11-347 301-05
16	91-009 934-05
17	91-053 671-21

Pos.-Nr. Item No. N° pos. N° de pos.	Teile-Nr. Part No. N° de piezas N° de pieza
18	91-000 380-15
19	91-044 251-21
20	91-000 824-25
21	91-040 624-25
22	91-028 036-25
23	91-001 592-25
24 - 29	91-043 943-70/895
24	91-043 124-71/895
25	11-470 355-15
26	91-043 946-25
27	91-043 945-75/895
28 - 29	91-043 947-92
29	91-000 388-15
30	91-046 727-23 5 95/8
31	91-056 384-05
32 - 33	91-712 488-92
33	91-173 664-15
34	91-100 366-15
35	91-000 422-25
36	91-000 781-15

-6/01 BN[◆]

-6/01-900/56 BN[◆]

Für allgemeine Näharbeiten.
 Standardform des Teilesatzes.

For plain seaming operations.
 Standard part set.

Travaux d'utilité courante.
 Jeu de pièces standard.

Para trabajos de costura en.
 Juego de piezas estándar.

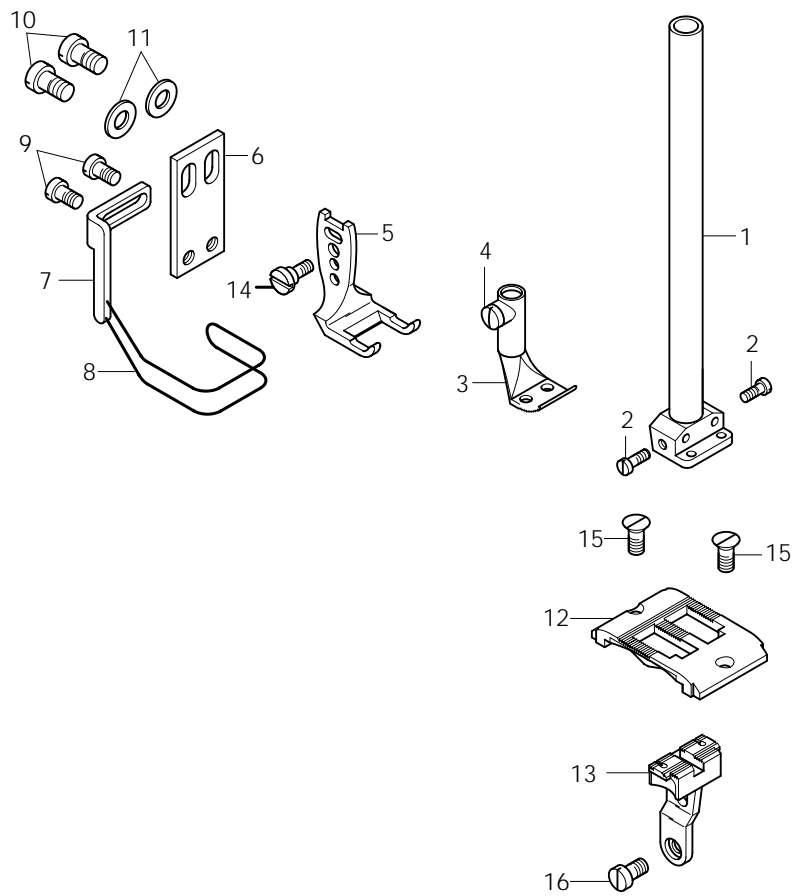

Pos.-Nr. Item No. N° pos. N° de pos.	Nadelabstand Needle gauge Ecartement de aiguilles Dist. entre aguja	Teile-Nr. (ohne -900/56) Part No. (without -900/56) N° de pieces (sans -900/56) N° de pieza (sin -900/56)	Teile-Nr. (mit -900/56) Part No. (with -900/56) N° de pieces (avec -900/56) N° de pieza (con -900/56)
1 - 13	8,0 12,0	91-202 138-93/007 91-202 138-93/004	91-202 139-93/008
1 - 2	2,4 3,2 4,8 6,0 6,4 7,2 8,0 9,2 10,0 11,2 12,0 12,8 14,0 16,0 18,0 20,0 22,0	91-710 749-93/003 91-710 749-93/006 91-710 749-93/009 91-710 749-93/011 91-710 749-93/012 91-710 749-93/015 91-710 749-93/016 91-710 749-93/017 91-710 749-93/031 91-710 749-93/019 91-710 749-93/021 91-710 749-93/025	91-710 749-93/001 91-710 749-93/003 91-710 749-93/006 91-710 749-93/009 91-710 749-93/010 91-710 749-93/011 91-710 749-93/012 91-710 749-93/013 91-710 749-93/015 91-710 749-93/016 91-710 749-93/017 91-710 749-93/019 91-710 749-93/021 91-710 749-93/023 91-710 749-93/025 91-710 749-93/026
2		91-173 664-15	91-173 664-15
3 - 4	2,4 3,2 4,8 6,0 6,4 7,2 8,0 10,0 11,2 12,0 14,0 16,0 18,0 20,0 22,0	91-049 267-93/035 91-049 267-93/036 91-049 267-93/037 91-049 267-93/039 91-049 267-93/040 91-049 267-93/041 91-049 267-93/042 91-049 267-93/043 91-049 267-93/044 91-049 267-93/053 91-049 267-93/067	91-049 267-93/001 91-049 267-93/035 91-049 267-93/036 91-049 267-93/037 91-049 267-93/038 91-049 267-93/039 91-049 267-93/040 91-049 267-93/041 91-049 267-93/042 91-049 267-93/043 91-049 267-93/044 91-049 267-93/053 91-049 267-93/045 91-049 267-93/067 91-049 267-93/070
4		91-000 085-15	91-000 085-15
5	2,4; 3,2 3,2 4,8 6,0 6,4 7,2; 8,0 9,2 10,0 11,2 12,0 12,8 14,0 16,0 18,0 20,0 22,0	91-040 429-04/005 91-040 429-04/006 91-040 429-04/007 91-040 429-04/008 91-040 429-04/010 91-040 429-04/011 91-040 429-04/012 91-040 429-04/012 91-040 429-04/013 91-040 429-04/015 91-040 429-04/018	91-040 429-04/041 91-040 429-04/006 91-040 429-04/007 91-040 429-04/007 91-040 429-04/008 91-040 429-04/008 91-040 429-04/009 91-040 429-04/010 91-040 429-04/011 91-040 429-04/012 91-040 429-04/013 91-040 429-04/015 91-040 429-04/017 91-040 429-04/018 91-040 429-04/020
6 - 9	2,4; 3,2 4,8; 6,0; 6,4; 7,2; 8,0; 9,2; 10,0; 11,2; 12,0; 12,8; 14,0 16,0; 18,0; 20,0; 22,0	91-057 741-91 91-057 806-91 91-057 809-91	91-057 741-91 91-057 806-91 91-057 809-91
6		91-057 720-15	91-057 720-15
7 - 8	2,4; 3,2	91-057 742-91	91-057 742-91

Pos.-Nr. Item No. N° pos. N° de pos.	Nadelabstand Needle gauge Ecartement de aiguilles Dist. entre aguja	Teile-Nr. (ohne -900/56) Part No. (without -900/56) N° de pieces (sans -900/56) N° de pieza (sin -900/56)	Teile-Nr. (mit -900/56) Part No. (with -900/56) N° de pieces (avec -900/56) N° de pieza (con -900/56)
	4,8; 6,0; 6,4; 7,2; 8,0; 9,2; 10,0; 11,2; 12,0; 12,8; 14,0 16,0; 18,0; 20,0; 22,0	91-057 807-91	91-057 807-91
		91-057 810-91	91-057 810-91
7	2,4; 3,2; 4,8; 6,0; 6,4; 7,2; 8,0; 9,2; 10,0; 11,2; 12,0; 12,8; 14,0 16,0; 18,0; 20,0; 22,0	91-154 702-15	91-154 702-15
		91-055 201-15	91-055 201-15
8	2,4; 3,2 4,8; 6,0; 6,4; 7,2; 8,0; 9,2; 10,0; 11,2; 12,0; 12,8; 14,0 16,0; 20,0	91-057 743-15 <input type="checkbox"/> 91-057 808-05 <input type="checkbox"/>	91-057 743-15 <input type="checkbox"/> 91-057 808-05 <input type="checkbox"/>
		91-057 811-05 <input type="checkbox"/>	91-057 811-05 <input type="checkbox"/>
9		11-108 171-15	11-108 171-15
10		11-108 222-15	11-108 222-15
11		12-305 144-15	12-305 144-15
12	2,4 3,2 4,8 6,0 6,4 7,2 8,0 9,2 10,0 11,2 12,0 14,0 16,0 18,0 20,0 22,0	91-150 724-04/025 91-150 724-04/021 91-150 724-04/018 91-150 724-04/023 91-150 724-04/004 91-150 724-04/012 91-150 724-04/007 91-150 724-04/020 91-150 724-04/014 91-150 724-04/022	91-158 056-04/001 91-158 056-04/002 91-158 056-04/004 91-158 056-04/006 91-158 056-04/008 91-158 056-04/010 91-158 056-04/012 91-158 056-04/014 91-158 056-04/016 91-158 056-04/018 91-158 056-04/020 91-158 056-04/022 91-158 056-04/024 91-158 056-04/027
13	2,4 3,2 4,8 6,0 6,4 7,2 8,0 10,0 11,2 12,0 12,8 14,0 16,0 18,0 20,0 22,0	91-059 991-04/028 91-059 991-04/013 91-059 991-04/014 91-059 991-04/015 91-059 991-04/005 91-059 991-04/016 91-059 991-04/017 91-059 991-04/008 91-059 991-04/018 91-059 991-04/019	91-059 175-04/001 91-059 175-04/002 91-059 175-04/004 91-059 175-04/006 91-059 175-04/008 91-059 175-04/010 91-059 175-04/012 91-059 175-04/014 91-059 175-04/016 91-059 175-04/018 91-059 175-04/020 91-059 175-04/022 91-059 175-04/024 91-059 175-04/027
14		91-100 366-15	91-100 366-15
15		91-000 277-25	91-000 277-25
16		91-000 781-15	91-000 781-15

-6/01 CN[◆]

-6/01-900/56 CN[◆]

Für allgemeine Näharbeiten.
 Standardform des Teilesatzes.

For plain seaming operations.
 Standard part set.

Travaux d'utilité courante.
 Jeu de pièces standard.

Para trabajos de costura en.
 Juego de piezas estándar.

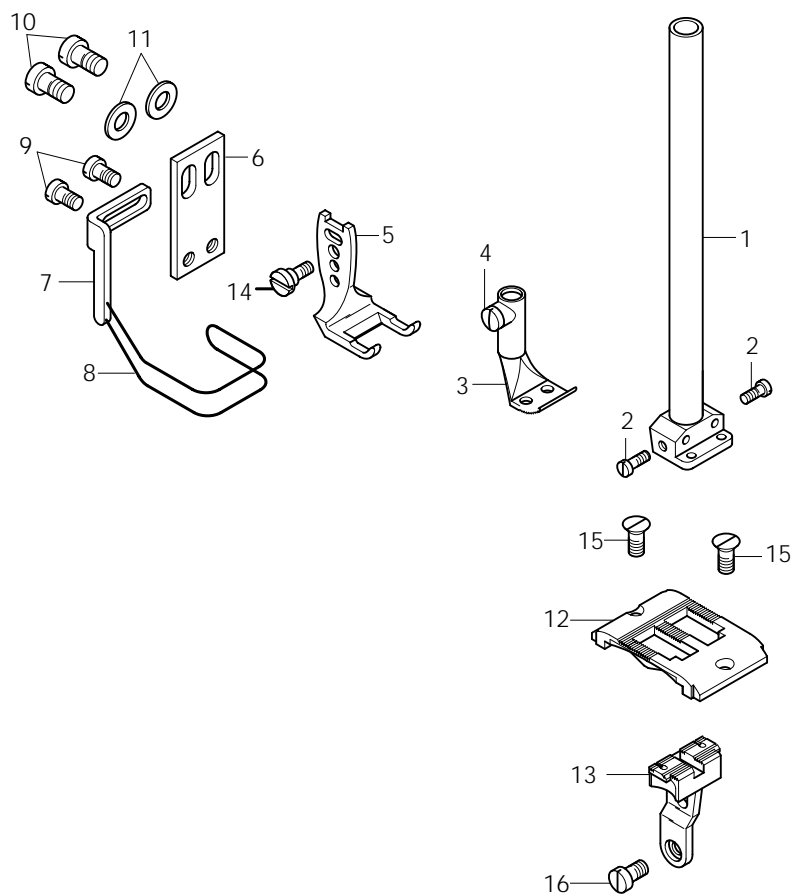

Pos.-Nr. Item No. N° de pos.	Nadelabstand Needle gauge Ecartement de aiguilles Dist. entre aguja	Teile-Nr. (ohne -900/56) Part No. (without -900/56) N° de pieces (sans -900/56) N° de pieza (sin -900/56)	Teile-Nr. (mit -900/56) Part No. (with -900/56) N° de pieces (avec -900/56) N° de pieza (con -900/56)
1 - 13	3,2 4,8 6,0 6,4 7,2 8,0 10,0 11,2 12,0 16,0 19,2	91-202 138-93/003 91-202 138-93/001 91-202 138-93/005 91-202 138-93/010 91-202 138-93/007 91-202 138-93/002 91-202 138-93/004 91-202 138-93/009 91-202 138-93/011	91-202 139-93/002 91-202 139-93/007 91-202 139-93/006 91-202 139-93/003 91-202 139-93/008 91-202 139-93/005 91-202 139-93/009 91-202 139-93/001 91-202 139-93/010
1 - 2	3,2 3,6 4,0 4,8 6,0 6,4 7,2 8,0 9,2 9,6 10,0 11,2 12,0 14,0 16,0 18,0 19,2 20,0 22,0	91-710 749-93/003 91-710 749-93/005 91-710 749-93/006 91-710 749-93/009 91-710 749-93/010 91-710 749-93/011 91-710 749-93/012 91-710 749-93/014 91-710 749-93/015 91-710 749-93/016 91-710 749-93/017 91-710 749-93/019 91-710 749-93/021 91-710 749-93/023 91-710 749-93/024 91-710 749-93/025	91-710 749-93/003 91-710 749-93/004 91-710 749-93/005 91-710 749-93/006 91-710 749-93/009 91-710 749-93/010 91-710 749-93/011 91-710 749-93/012 91-710 749-93/013 91-710 749-93/015 91-710 749-93/016 91-710 749-93/017 91-710 749-93/019 91-710 749-93/021 91-710 749-93/023 91-710 749-93/025 91-710 749-93/026
2		91-173 664-15	91-173 664-15
3 - 4	3,2 3,6 4,0 4,8 6,0 6,4 7,2 8,0 9,2 9,6 10,0 11,2 12,0 14,0 16,0 18,0 19,2 20,0 22,0	91-049 267-93/002 91-049 267-93/003 91-049 267-93/004 91-049 267-93/005 91-049 267-93/006 91-049 267-93/007 91-049 267-93/008 91-049 267-93/030 91-049 267-93/010 91-049 267-93/032 91-049 267-93/011 91-049 267-93/012 91-049 267-93/013 91-049 267-93/014 91-049 267-93/031 91-049 267-93/015	91-049 267-93/002 91-049 267-93/401 91-049 267-93/003 91-049 267-93/004 91-049 267-93/005 91-049 267-93/006 91-049 267-93/007 91-049 267-93/008 91-049 267-93/009 91-049 267-93/010 91-049 267-93/032 91-049 267-93/011 91-049 267-93/012 91-049 267-93/013 91-049 267-93/014 91-049 267-93/031 91-049 267-93/015 91-049 267-93/016
4		91-000 085-15	91-000 085-15
5	3,2 3,2 3,6; 4,0 4,8 6,0; 6,4 7,2; 8,0 9,2 9,6; 10,0 11,2 12,0 14,0 16,0 18,0 19,2; 20,0 22,0	91-040 429-04/005 91-040 429-04/005 91-040 429-04/006 91-040 429-04/007 91-040 429-04/008 91-040 429-04/010 91-040 429-04/011 91-040 429-04/012 91-040 429-04/013 91-040 429-04/015 91-040 429-04/017 91-040 429-04/018 91-040 429-04/020	91-040 429-04/041 91-040 429-04/005 91-040 429-04/006 91-040 429-04/007 91-040 429-04/008 91-040 429-04/009 91-040 429-04/010 91-040 429-04/011 91-040 429-04/012 91-040 429-04/013 91-040 429-04/015 91-040 429-04/017 91-040 429-04/018
6 - 9	3,2;3,6;4,0 4,8;6,0;6,4; 7,2;8,0;9,2; 9,6;10,0; 11,2;12,0; 14,0 16,0;18,0; 19,2;20,0; 22,0	91-057 741-91 91-057 806-91 91-057 809-91	91-057 741-91 91-057 806-91 91-057 809-91

Pos.-Nr. Item No. N° de pos.	Nadelabstand Needle gauge Ecartement de aiguilles Dist. entre aguja	Teile-Nr. (ohne -900/56) Part No. (without -900/56) N° de pieces (sans -900/56) N° de pieza (sin -900/56)	Teile-Nr. (mit -900/56) Part No. (with -900/56) N° de pieces (avec -900/56) N° de pieza (con -900/56)
6		91-057 720-15	91-057 720-15
7 - 8	3,2;3,6;4,0 4,8;6,0;6,4; 7,2;8,0;9,2; 9,6;10,0; 11,2;12,0; 14,0 16,0;18,0; 19,2;20,0; 22,0	91-057 742-91 91-057 807-91 91-057 810-91	91-057 742-91 91-057 807-91 91-057 810-91
7	3,2;3,6;4,0; 4,8;6,0;6,4; 7,2;8,0;9,2; 9,6;10,0; 11,2;12,0; 14,0 16,0;18,0; 19,2;20,0; 22,0	91-154 702-15 91-055 201-15	91-154 702-15 91-055 201-15
8	3,2;3,6;4,0 4,8;6,0;6,4; 7,2;8,0;9,2; 9,6;10,0; 11,2;12,0; 14,0 16,0;18,0; 19,2;20,0; 22,0	91-057 743-15 <input type="checkbox"/> 91-057 808-05 <input type="checkbox"/> 91-057 811-05 <input type="checkbox"/>	91-057 743-15 <input type="checkbox"/> 91-057 808-05 <input type="checkbox"/> 91-057 811-05 <input type="checkbox"/>
9		11-108 171-15	11-108 171-15
10		11-108 222-15	11-108 222-15
11		12-305 144-15	12-305 144-15
12	3,2 3,6 4,0 4,8 6,0 6,4 7,2 8,0 9,2 9,6 10,0 11,2 12,0 14,0 16,0 18,0 19,2 20,0 22,0	91-150 724-04/011 91-150 724-04/001 91-150 724-04/002 91-150 724-04/003 91-150 724-04/005 91-150 724-04/019 91-150 724-04/006 91-150 724-04/024 91-150 724-04/008 91-150 724-04/013 91-150 724-04/009 91-150 724-04/015 91-150 724-04/010 91-150 724-04/016 91-150 724-04/017	91-158 056-04/003 91-158 056-04/402 91-158 056-04/026 91-158 056-04/005 91-158 056-04/007 91-158 056-04/009 91-158 056-04/011 91-158 056-04/013 91-158 056-04/028 91-158 056-04/015 91-158 056-04/029 91-158 056-04/017 91-158 056-04/019 91-158 056-04/021 91-158 056-04/023 91-158 056-04/025
13	3,2 3,6 4,0 4,8 6,0 6,4 7,2 8,0 9,2 9,6 10,0 11,2 12,0 14,0 16,0 18,0 19,2 20,0	91-059 991-04/001 91-059 991-04/029 91-059 991-04/020 91-059 991-04/002 91-059 991-04/003 91-059 991-04/004 91-059 991-04/006 91-059 991-04/021 91-059 991-04/007 91-059 991-04/022 91-059 991-04/009 91-059 991-04/023 91-059 991-04/010 91-059 991-04/024 91-059 991-04/011 91-059 991-04/025	91-059 175-04/003 91-059 175-04/401 91-059 175-04/026 91-059 175-04/005 91-059 175-04/007 91-059 175-04/009 91-059 175-04/011 91-059 175-04/013 91-059 175-04/028 91-059 175-04/015 91-059 175-04/029 91-059 175-04/017 91-059 175-04/019 91-059 175-04/021 91-059 175-04/023 91-059 175-04/025
14		91-100 366-15	91-100 366-15
15		91-000 277-25	91-000 277-25
16		91-000 781-15	91-000 781-15

-63/14 CN♦

-63/14-900/56 CN♦

Arbeitsgang
 Operation
 Opération
 Operación

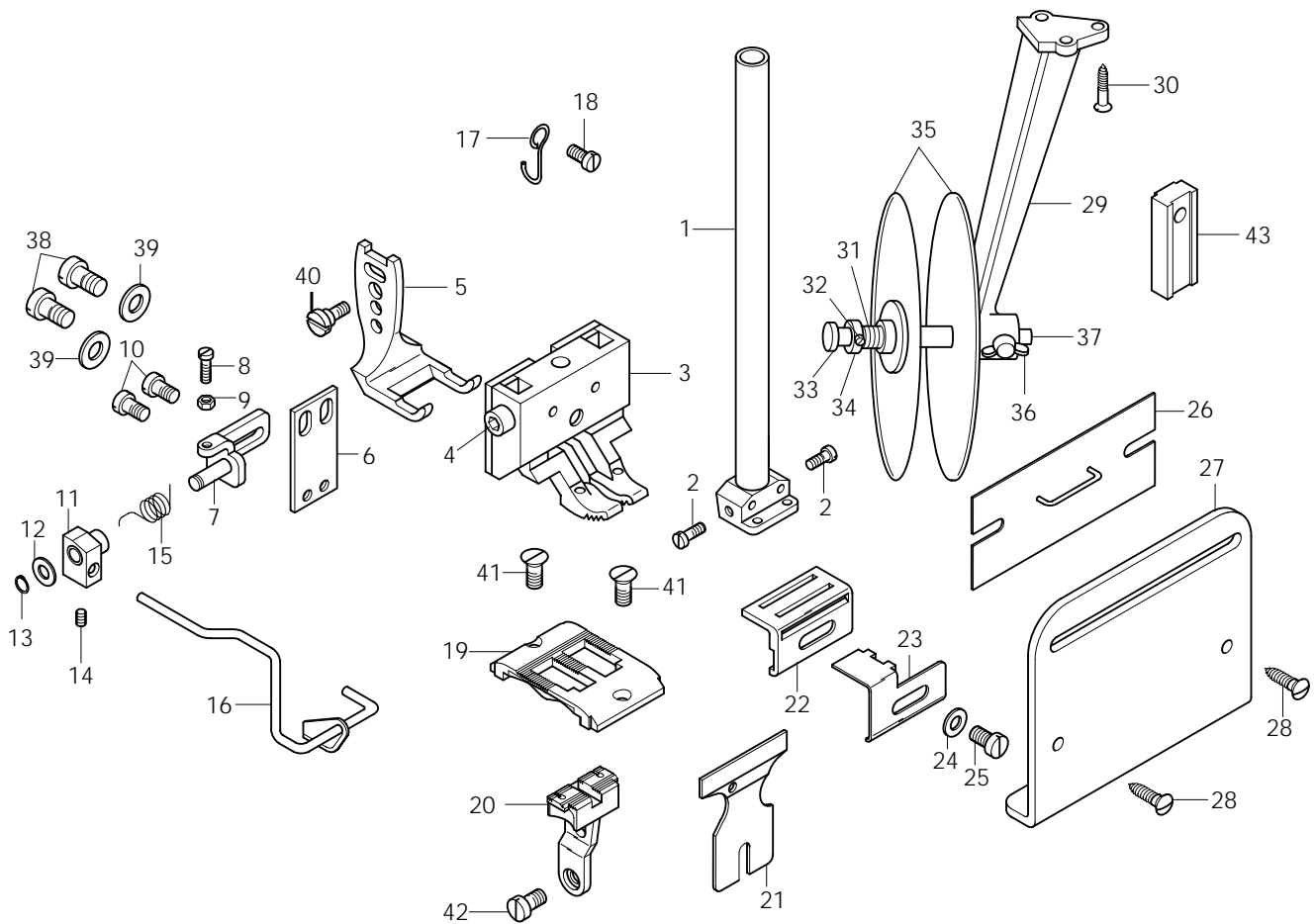
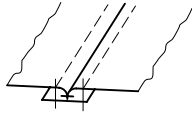

Pos.-Nr. Item No. N° pos. N° de pos.	Nadelabstand Needle gauge Ecartement de aiguilles Dist. entre aguja	Teile-Nr. (ohne -900/56) Part No. (without -900/56) N° de pieces (sans -900/56) N° de pieza (sin -900/56)	Teile-Nr. (mit -900/56) Part No. (with -900/56) N° de pieces (avec -900/56) N° de pieza (con -900/56)
1 - 26	8,0 10,0	91-202 140-93/001	91-202 141-93/001 91-202 141-93/002
1 - 2	3,2 3,6 4,0 4,8 6,0 6,4 7,2 8,0 9,2 9,6 10,0 11,2 12,0 14,0 16,0 18,0 19,2 20,0 22,0	91-710 749-93/003 91-710 749-93/005 91-710 749-93/006 91-710 749-93/009 91-710 749-93/010 91-710 749-93/011 91-710 749-93/012 91-710 749-93/014 91-710 749-93/015 91-710 749-93/016 91-710 749-93/017 91-710 749-93/019 91-710 749-93/021 91-710 749-93/023 91-710 749-93/024 91-710 749-93/025 91-710 749-93/026	91-710 749-93/003 91-710 749-93/004 91-710 749-93/005 91-710 749-93/006 91-710 749-93/009 91-710 749-93/010 91-710 749-93/011 91-710 749-93/012 91-710 749-93/013 91-710 749-93/015 91-710 749-93/016 91-710 749-93/017 91-710 749-93/019 91-710 749-93/021 91-710 749-93/023 91-710 749-93/025
2		91-173 664-15	91-173 664-15
3 - 4	6,0 7,2 8,0 9,2 10,0 12,0 14,0 16,0	91-149 152-93/008 91-149 152-93/005 91-149 152-93/003 91-149 152-93/001 91-149 152-93/004 91-149 152-93/009 91-149 152-93/010	91-149 152-93/008 91-149 152-93/005 91-149 152-93/003 91-149 152-93/007 91-149 152-93/001 91-149 152-93/004 91-149 152-93/009 91-149 152-93/010
4		11-130 185-15	11-130 185-15
5	6,0;6,4;7,2; 8,0 10,0 12,0 14,0	91-049 998-04/001 91-049 998-04/003 91-049 998-04/004 91-049 998-04/002	91-049 998-04/001 91-049 998-04/003 91-049 998-04/0014 91-049 998-04/002
6 - 16		91-156 614-91	91-156 614-91
6		91-057 720-15	91-057 720-15
7		91-156 597-91	91-156 597-91
8		11-108 099-15	11-108 099-15
9		12-024 121-25	12-024 121-25
10		11-130 167-15	11-130 167-15
11		91-156 605-05	91-156 605-05
12		12-360 033-05	12-360 033-05
13		12-610 170-45	12-610 170-45
14		11-330 085-15	11-330 085-15
15		91-156 606-05	91-156 606-05
16		91-156 602-11	91-156 602-11
17		91-149 112-05	91-149 112-05
18		11-108 174-15	11-108 174-15
19	3,2 3,6 4,0 4,8 6,0 6,4 7,2 8,0 9,2 9,6 10,0	91-150 724-04/011 91-150 724-04/001 91-150 724-04/002 91-150 724-04/003 91-150 724-04/005 91-150 724-04/019 91-150 724-04/006	91-158 056-04/003 91-158 056-04/402 91-158 056-04/026 91-158 056-04/005 91-158 056-04/007 91-158 056-04/009 91-158 056-04/011 91-158 056-04/013 91-158 056-04/028 91-158 056-04/015

Pos.-Nr. Item No. N° pos. N° de pos.	Nadelabstand Needle gauge Ecartement de aiguilles Dist. entre aguja	Teile-Nr. (ohne -900/56) Part No. (without -900/56) N° de pieces (sans -900/56) N° de pieza (sin -900/56)	Teile-Nr. (mit -900/56) Part No. (with -900/56) N° de pieces (avec -900/56) N° de pieza (con -900/56)
	11,2 12,0 14,0 16,0 18,0 19,2 20,0 22,0	91-150 724-04/024 91-150 724-04/008 91-150 724-04/013 91-150 724-04/009 91-150 724-04/015 91-150 724-04/010 91-150 724-04/016 91-150 724-04/017	91-158 056-04/029 91-158 056-04/017 91-158 056-04/019 91-158 056-04/021 91-158 056-04/023 91-158 056-04/025
20	3,2 3,6 4,0 4,8 6,0 6,4 7,2 8,0 9,2 9,6 10,0 11,2 12,0 14,0 16,0 18,0 19,2 20,0	91-059 991-04/001 91-059 991-04/029 91-059 991-04/020 91-059 991-04/002 91-059 991-04/003 91-059 991-04/004 91-059 991-04/006 91-059 991-04/021 91-059 991-04/007 91-059 991-04/022 91-059 991-04/009 91-059 991-04/023 91-059 991-04/010 91-059 991-04/024 91-059 991-04/025	91-059 175-04/003 91-059 175-04/401 91-059 175-04/026 91-059 175-04/005 91-059 175-04/007 91-059 175-04/009 91-059 175-04/011 91-059 175-04/013 91-059 175-04/028 91-059 175-04/015 91-059 175-04/029 91-059 175-04/017 91-059 175-04/019 91-059 175-04/021 91-059 175-04/023 91-059 175-04/025
21 - 25		91-041 182-91	91-041 182-91
21		91-053 069-25	91-053 069-25
22		91-053 070-21	91-053 070-21
23		91-053 073-25	91-053 073-25
24		12-315 110-15	12-315 110-15
25		91-000 089-25	91-000 089-25
26		91-042 211-21	91-042 211-21
27		91-044 419-25	91-044 419-25
28		11-470 109-25	11-470 109-25
29 - 37		91-041 644-70/895	91-041 644-70/895
29		91-026 558-75/895	91-026 558-75/895
30		11-470 355-15	11-470 355-15
31		91-025 694-05	91-025 694-05
32		91-000 388-15	91-000 388-15
33		91-043 143-25	91-043 143-25
34		91-043 191-92	91-043 191-92
35		91-043 138-71/895	91-043 138-71/895
36		11-505 292-25	11-505 292-25
37		91-043 148-21	91-043 148-21
38		11-108 222-15	11-108 222-15
39		12-305 144-15	12-305 144-15
40		91-100 366-15	91-100 366-15
41		91-000 277-25	91-000 277-25
42		91-000 781-15	91-000 781-15
43		91-156 709-05	91-156 709-05

-63/15 CN[◆]

-63/15-900/56 CN[◆]

Arbeitsgang
 Operation
 Opération
 Operación

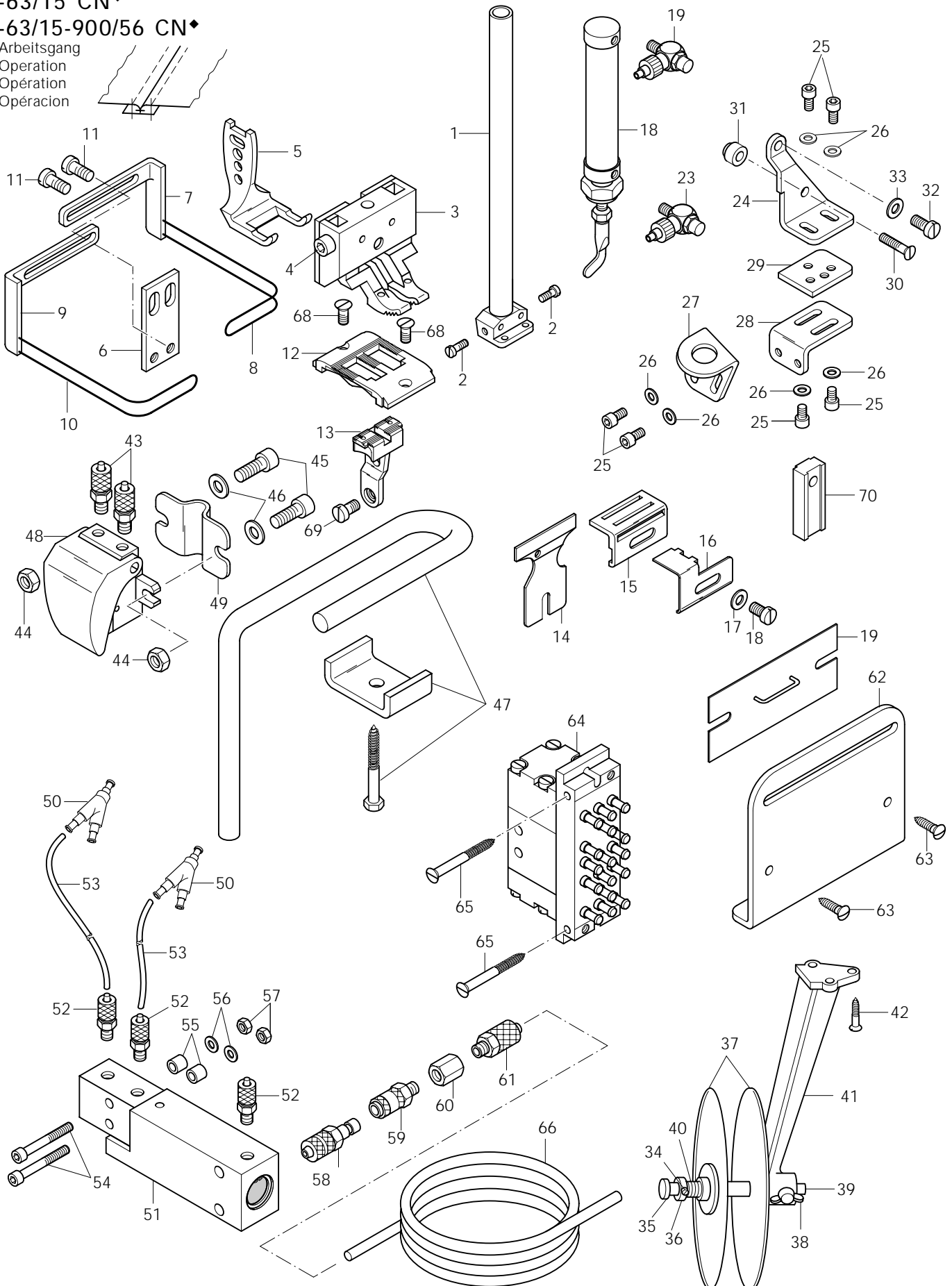

Pos.-Nr. Item No. N° pos. N° de pos.	Nadelabstand Needle gauge Ecartement de aiguilles Dist. entre aguja	Teile-Nr. (ohne -900/56) Part No. (without -900/56) N° de pieces (sans -900/56) N° de pieza (sin -900/56)	Teile-Nr. (mit -900/56) Part No. (with -900/56) N° de pieces (avec -900/56) N° de pieza (con -900/56)	Pos.-Nr. Item No. N° pos. N° de pos.	Nadelabstand Needle gauge Ecartement de aiguilles Dist. entre aguja	Teile-Nr. (ohne -900/56) Part No. (without -900/56) N° de pieces (sans -900/56) N° de pieza (sin -900/56)	Teile-Nr. (mit -900/56) Part No. (with -900/56) N° de pieces (avec -900/56) N° de pieza (con -900/56)
1 - 26	6,0 8,0 10,0 12,0	91-202 298-93/004 91-202 298-93/001 91-202 298-93/002 91-202 298-93/003	91-202 297-93/003 91-202 297-93/002 91-202 297-93/001		9,2 9,6 10,0 11,2 12,0 14,0 16,0 18,0 19,2 20,0	91-059 991-04/021 91-059 991-04/007 91-059 991-04/022 91-059 991-04/009 91-059 991-04/023 91-059 991-04/010 91-059 991-04/024 91-059 991-04/011 91-059 991-04/025	91-059 175-04/028 91-059 175-04/015 91-059 175-04/029 91-059 175-04/017 91-059 175-04/019 91-059 175-04/021 91-059 175-04/023
1 - 2	3,2 3,6 4,0 4,8 6,0 6,4 7,2 8,0 9,2 9,6 10,0 11,2 12,0 14,0 16,0 18,0 19,2 20,0 22,0	91-710 749-93/003 91-710 749-93/005 91-710 749-93/006 91-710 749-93/009 91-710 749-93/010 91-710 749-93/011 91-710 749-93/012 91-710 749-93/014 91-710 749-93/015 91-710 749-93/016 91-710 749-93/017 91-710 749-93/019 91-710 749-93/021 91-710 749-93/023 91-710 749-93/024 91-710 749-93/025 91-710 749-93/026	91-710 749-93/003 91-710 749-93/004 91-710 749-93/005 91-710 749-93/006 91-710 749-93/009 91-710 749-93/010 91-710 749-93/011 91-710 749-93/012 91-710 749-93/013 91-710 749-93/015 91-710 749-93/016 91-710 749-93/017 91-710 749-93/019 91-710 749-93/021 91-710 749-93/023 91-710 749-93/025				
2		91-173 664-15		14 - 18		91-041 182-91	91-041 182-91
3 - 4	6,0 7,2 8,0 9,2 10,0 12,0 14,0 16,0	91-149 152-93/008 91-149 152-93/005 91-149 152-93/003 91-149 152-93/001 91-149 152-93/004 91-149 152-93/009 91-149 152-93/010	91-149 152-93/008 91-149 152-93/005 91-149 152-93/003 91-149 152-93/007 91-149 152-93/001 91-149 152-93/004 91-149 152-93/009 91-149 152-93/010	14		91-053 069-25	91-053 069-25
4		11-130185-15		15		91-053 070-21	91-053 070-21
5	6,0;6,4; 7,2;8,0 10,0 12,0 14,0	91-049 998-04/001 91-049 998-04/003 91-049 998-04/004 91-049 998-04/002	91-049 998-04/001 91-049 998-04/003 91-049 998-04/004 91-049 998-04/002	16		91-053 073-25	91-053 073-25
6 - 11		91-154 776-91 91-057 720-15	91-154 776-91 91-057 720-15	17		12-315 110-15	12-315 110-15
6		91-154 715-91	91-154 715-91	18		91-000 089-25	91-000 089-25
7 - 8		91-154 717-15	91-154 717-15	19		91-042 211-21	91-042 211-21
7		91-154 716-05 [3]	91-154 716-05 [3]	20 - 33		91-156 731-90	91-156 731-90
8		91-154 712-91	91-154 712-91	20 - 21		91-156 741-91	91-156 741-91
9 - 10		91-154 714-15	91-154 714-15	20		99-137 352-91	99-137 352-91
9		91-154 713-05 [3]	91-154 713-05 [3]	21		91-156 742-05	91-156 742-05
10		11-108-174-15	11-108-174-15	22		99-135 233-91	99-135 233-91
11				23		99-135 490-91	99-135 490-91
12	3,2 3,6 4,0 4,8 6,0 6,4 7,2 8,0 9,2 9,6 10,0 11,2 12,0 14,0 16,0 18,0 19,2 20,0 22,0	91-150 724-04/011 91-150 724-04/001 91-150 724-04/002 91-150 724-04/003 91-150 724-04/005 91-150 724-04/019 91-150 724-04/006 91-150 724-04/024 91-150 724-04/008 91-150 724-04/013 91-150 724-04/009 91-150 724-04/015 91-150 724-04/010 91-150 724-04/016 91-150 724-04/017	91-158 056-04/003 91-158 056-04/402 91-158 056-04/026 91-158 056-04/005 91-158 056-04/007 91-158 056-04/009 91-158 056-04/011 91-158 056-04/013 91-158 056-04/028 91-158 056-04/015 91-158 056-04/029 91-158 056-04/017 91-158 056-04/019 91-158 056-04/021 91-158 056-04/023 91-158 056-04/025	24 - 29		91-156 743-21	91-156 743-21
13	3,2 3,6 4,0 4,8 6,0 6,4 7,2 8,0	91-059 991-04/001 91-059 991-04/029 91-059 991-04/020 91-059 991-04/002 91-059 991-04/003 91-059 991-04/004 91-059 991-04/006	91-059 175-04/003 91-059 175-04/401 91-059 175-04/026 91-059 175-04/005 91-059 175-04/007 91-059 175-04/009 91-059 175-04/011 91-059 175-04/013	24		91-156 744-25	91-156 744-25
				25		11-130 170-25	11-130 170-25
				26		12-305 114-25	12-305 114-25
				27		91-156 713-25	91-156 713-25
				28		91-156 745-25	91-156 745-25
				29		91-156 746-25	91-156 746-25
				30		11-210 178-25	11-210 178-25
				31		91-156 729-25	91-156 729-25
				32		11-108 222-15	11-108 222-15
				33		12-305 144-15	12-305 144-15
				34 - 42		91-041 644-70/895	91-041 644-70/895
				34		91-000 388-15	91-000 388-15
				35		91-043 143-25	91-043 143-25
				36		91-043 191-92	91-043 191-92
				37		91-043 138-71/895	91-043 138-71/895
				38		11-505 292-25	11-505 292-25
				39		91-043 148-21	91-043 148-21
				40		91-025 694-05	91-025 694-05
				41		91-026 558-75/895	91-026 558-75/895
				42		11-470 355-15	11-470 355-15
				43 - 53		91-265 109-90	91-265 109-90
				43		99-115 425-91	99-115 425-91
				44		12-024 191-25	12-024 191-25
				45		11-130 293-25	11-130 293-25
				46		12-305 174-25	12-305 174-25
				47		99-136 964-91	99-136 964-91
				48		99-136 963-91	99-136 963-91
				49		91-265 072-05	91-265 072-05
				50 - 53		91-089 570-91	91-089 570-91
				50		99-135 002-95	99-135 002-95
				51		99-134 580-91	99-134 580-91
				52		99-115 425-91	99-115 425-91
				53		25-308 820-30 [96]	25-308 820-30 [96]
				54		11-130 203-15	11-130 203-15
				55		91-087 293-15	91-087 293-15
				56		12-305 114-15	12-305 114-15
				57		12-024 151-25	12-024 151-25
				58		99-134 256-91	99-134 256-91
				59		99-134 255-91	99-134 255-91
				60		99-134 206-05	99-134 206-05
				61		99-135 911-91	99-135 911-91
				62		91-044 419-25	91-044 419-25
				63		11-470 109-25	11-470 109-25
				64		99-135 016-91	99-135 016-91
				65		11-460 211-15	11-460 211-15
				66		25-308 820-30 [96]	25-308 820-30 [96]
				67		91-100 366-15	91-100 366-15
				68		91-000 277-25	91-000 277-25
				69		91-000 781-15	91-000 781-15
				70		91-156 709-05	91-156 709-05

-2/01-900/56 CN[◆]

Zum Übersteppen von Seitennähten im Hüftbogenbereich bei Jeans etc. Spezialteilesatz mit Anschlägen für rechte und linke Teile.

For top.stitching side seams in the hip curve on jeans, etc. Special part set with edge guides for right- and left parts.

Pour le surpiquage de coutures de côtés sur l'arrondi de la hanche pour les jeans, etc., jeu de pièces spécial avec butées pour pièces de droite et de gauche.

Para sobrepespuntar las costuras laterales en la zona de las caderas de vaqueros etc., juego de piezas especial con topos para oiezas izquierdas y derechas.

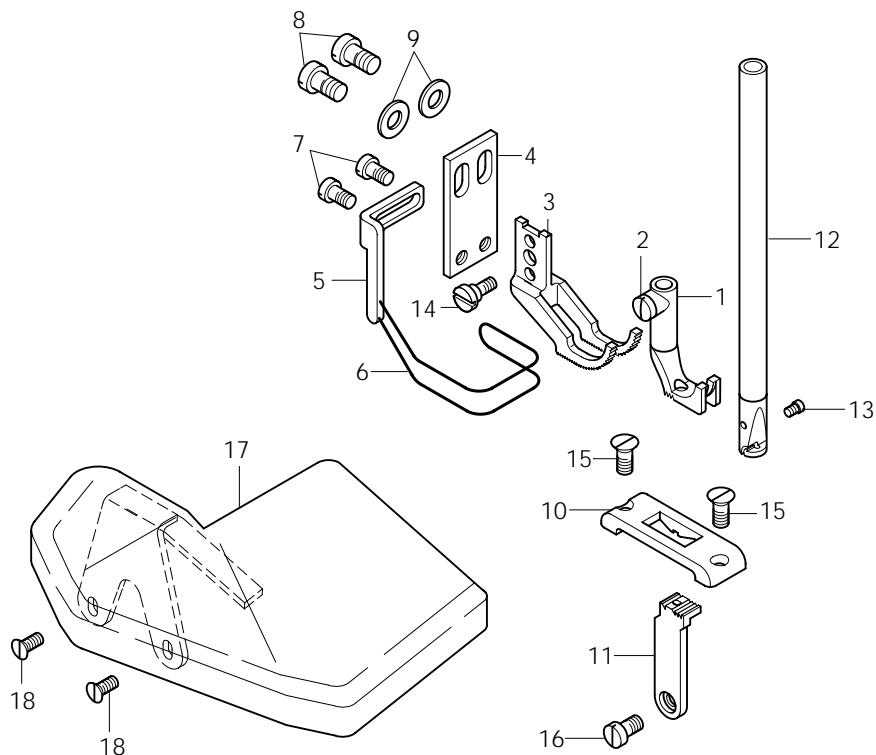

Pos.-Nr. Item No. N° pos. N° de pos.	Teile-Nr. Part No. N° de pièces N° de pieza
1 - 11	91-202 189-93/002
1 - 2	91-149 200-93/001
2	91-000 085-15
3	91-049 792-04/004
4 - 7	91-057 806-91
4	91-057 720-15
5 - 6	91-057 807-91
5	91-154 702-15
6	91-057 808-05 3
7	11-108 171-15
8	11-108 222-15

Pos.-Nr. Item No. N° pos. N° de pos.	Teile-Nr. Part No. N° de pièces N° de pieza
9	12-305 144-15
10	91-158 292-05
11	91-059 254-04/001
12 - 13	91-710 650-92
13	91-173 664-15
14	91-100 366-15
15	91-000 277-25
16	91-000 781-15
17	91-141 854-21
18	91-000 172-15

PFAFF

PFAFF Industrie Maschinen GmbH

Postfach 3020
D-67653 Kaiserslautern

Königstr. 154
D-67655 Kaiserslautern

Telefon: (0631) 200-0
Telefax: (0631) 17202
E-Mail: info@pfaff-industrial.com

Gedruckt in der BRD
Printed in Germany
Imprimé en R.F.A.
Impreso en la R.F.A.